

# **Interactive 3D Data Exploration using Hybrid Tactile/Tangible Interaction**

Lonni Besançon, Paul Issartel, Mehdi Ammi, Tobias Isenberg

# Problem

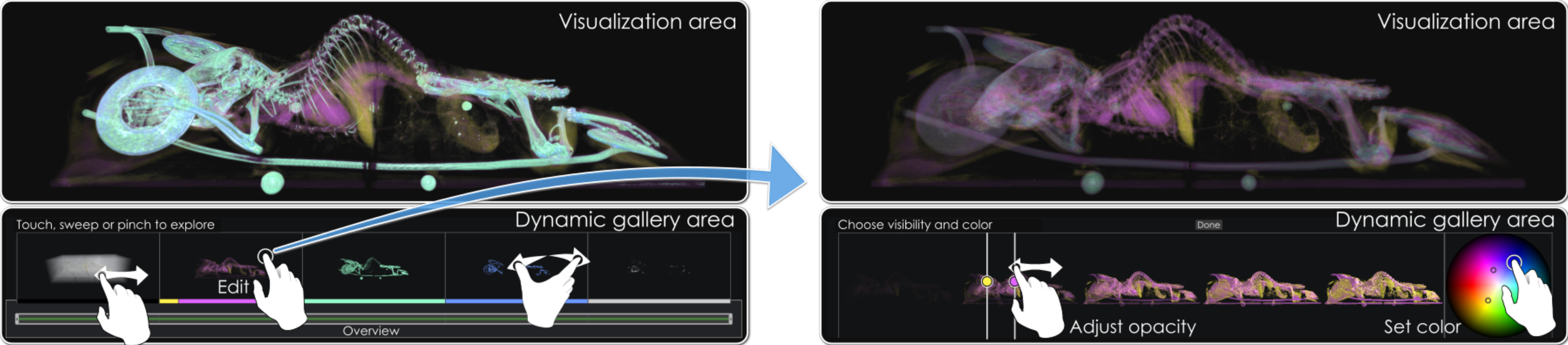

Jönsson et al. (2016)

# Problem

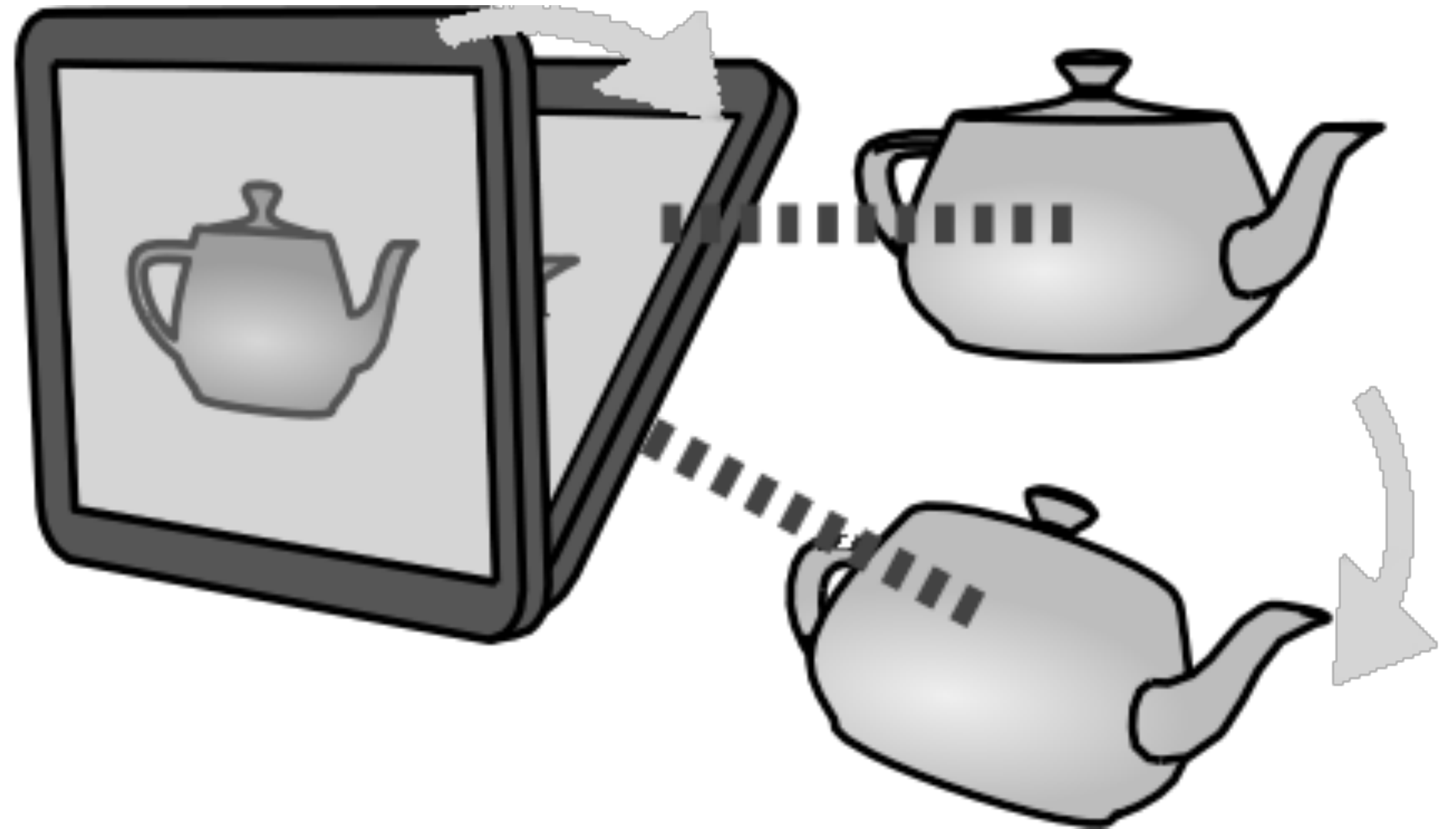
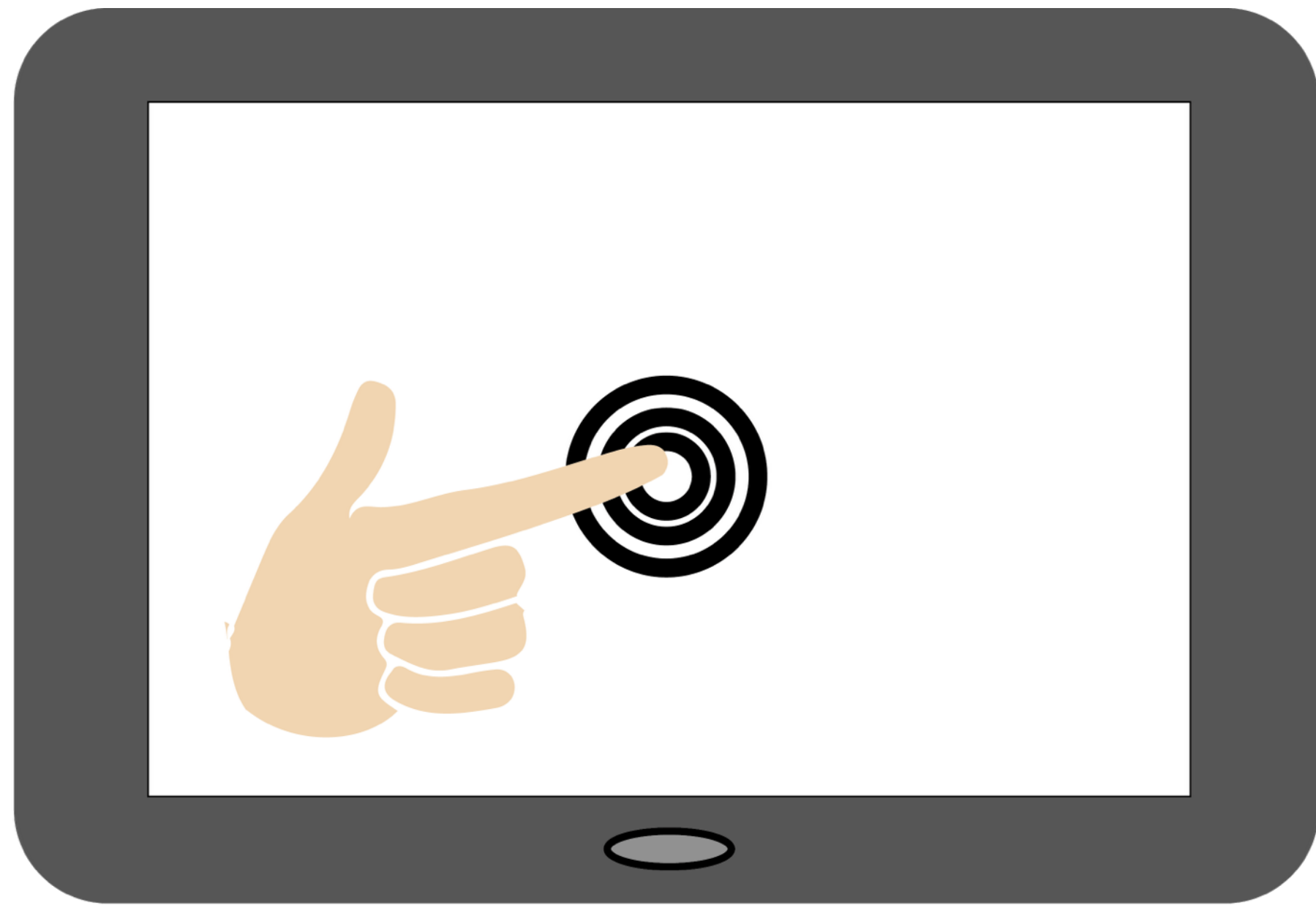

# Tactile interaction



Yu et al. (2010)

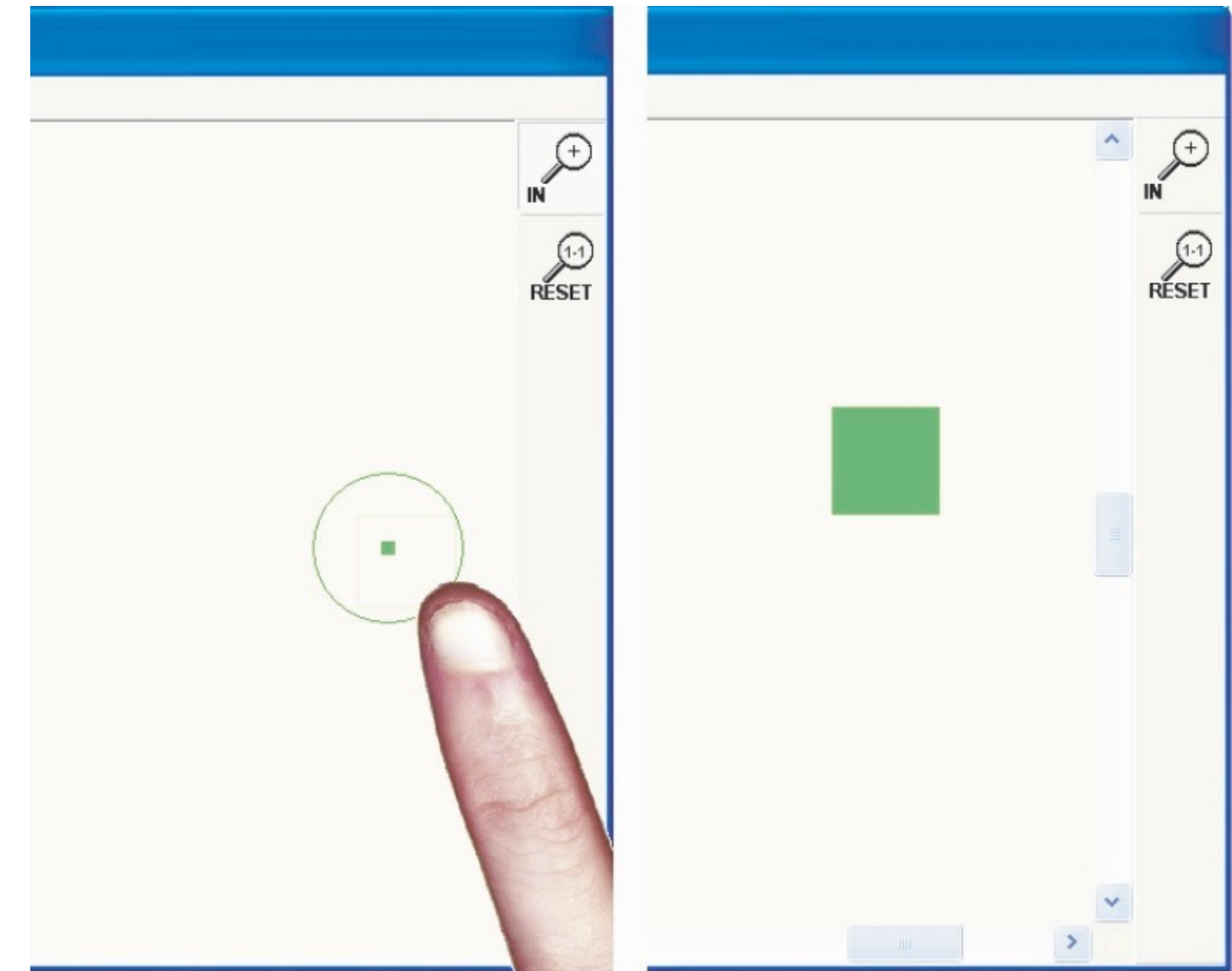

Albinson & Zhai. (2003)

# Tactile interaction

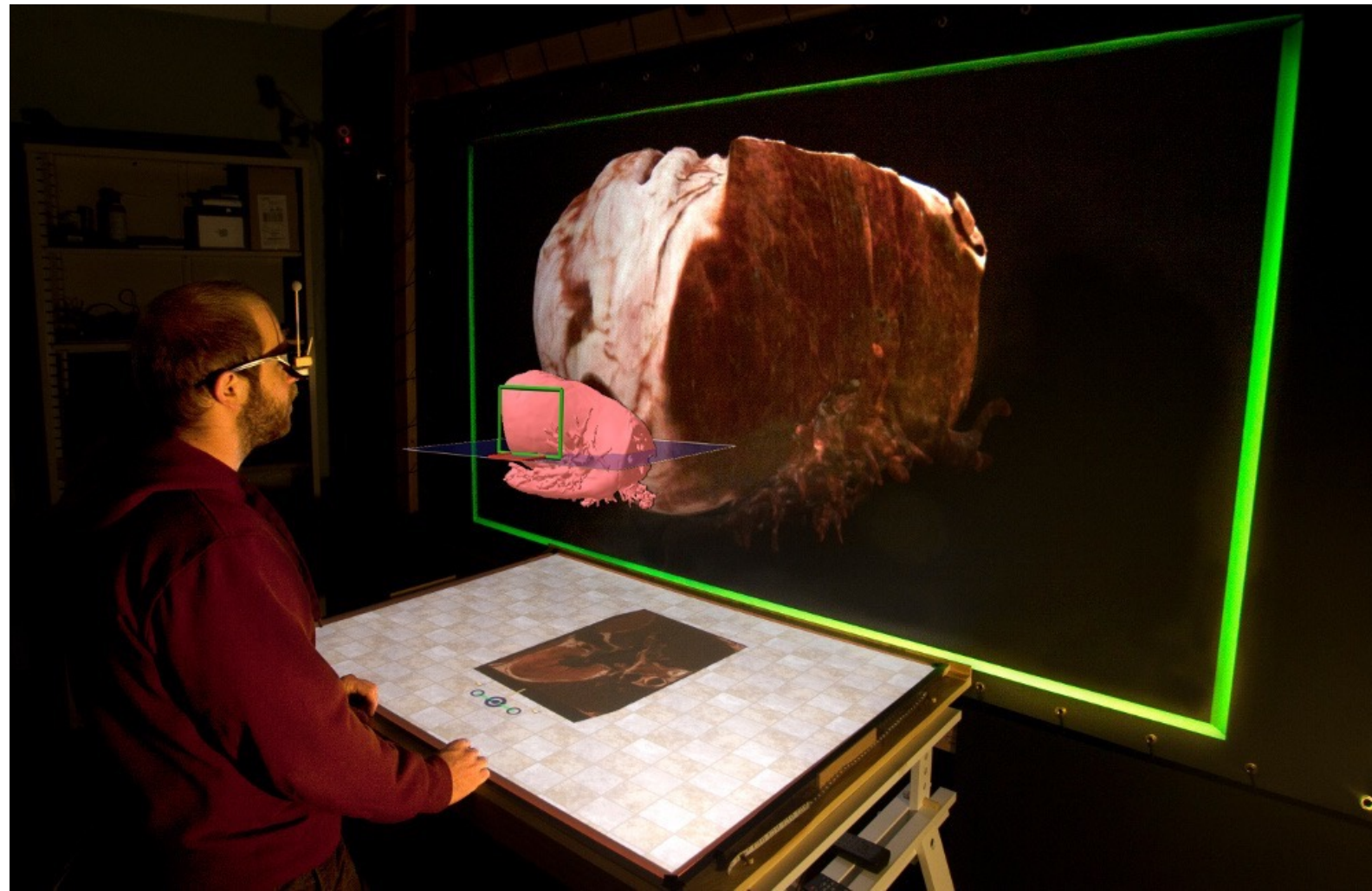

Coffey et al. (2012)

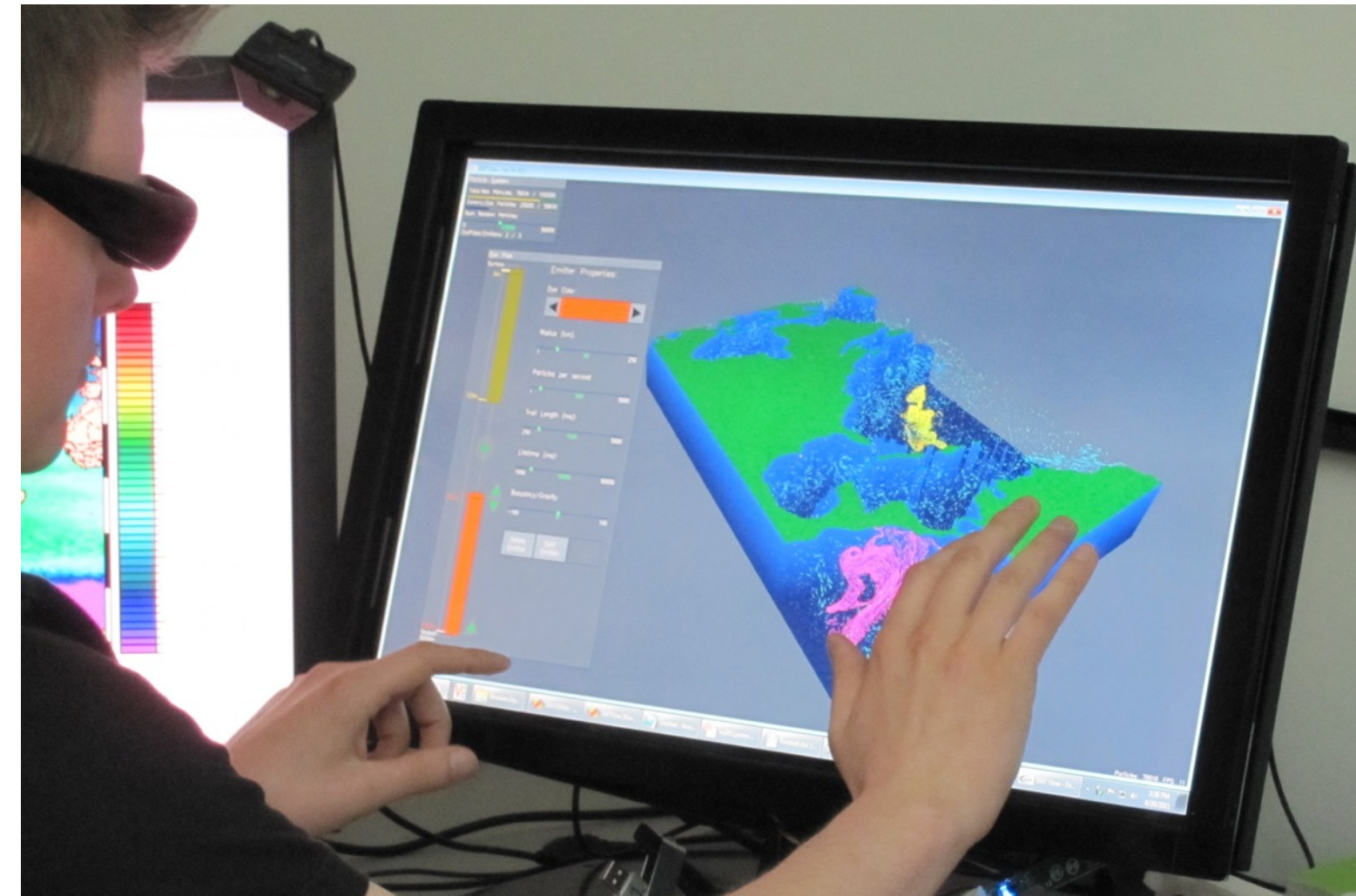

Butkiewicz & Ware (2012)

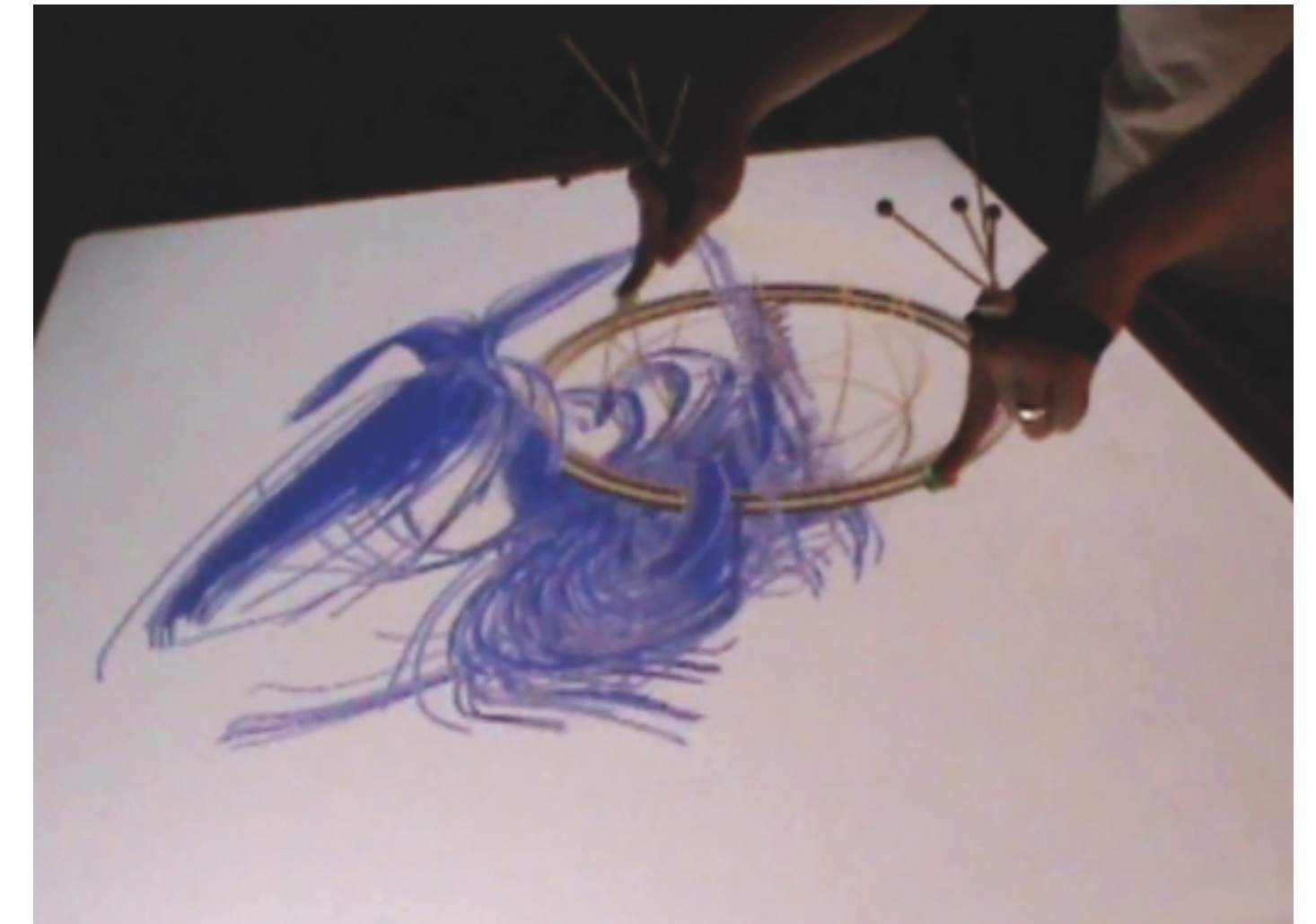

Jackson et al. (2012)

# Tangible Interaction

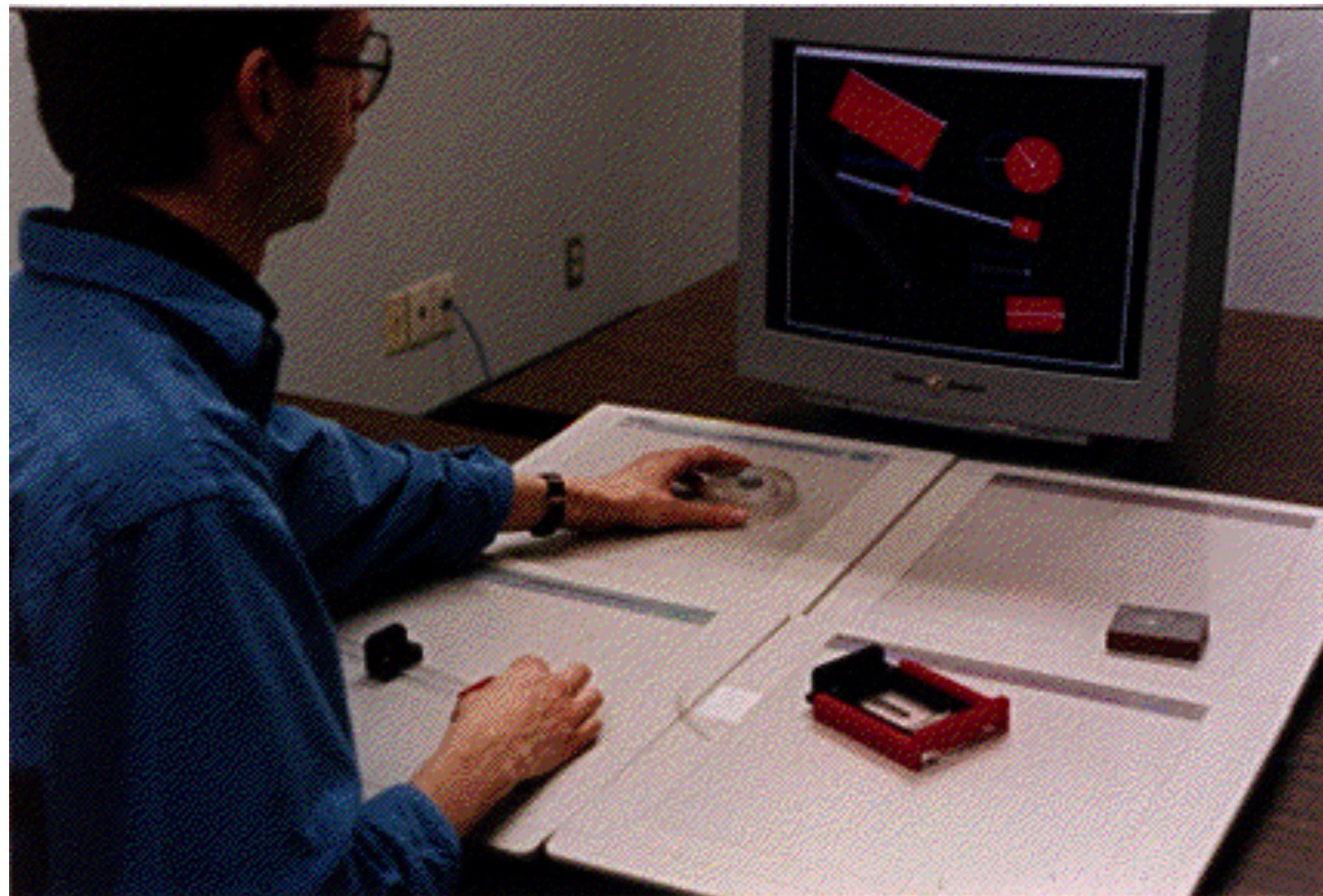

Fitzmaurice & Buxton (1997)



Besançon et al. (2015)

# Tangible Interaction

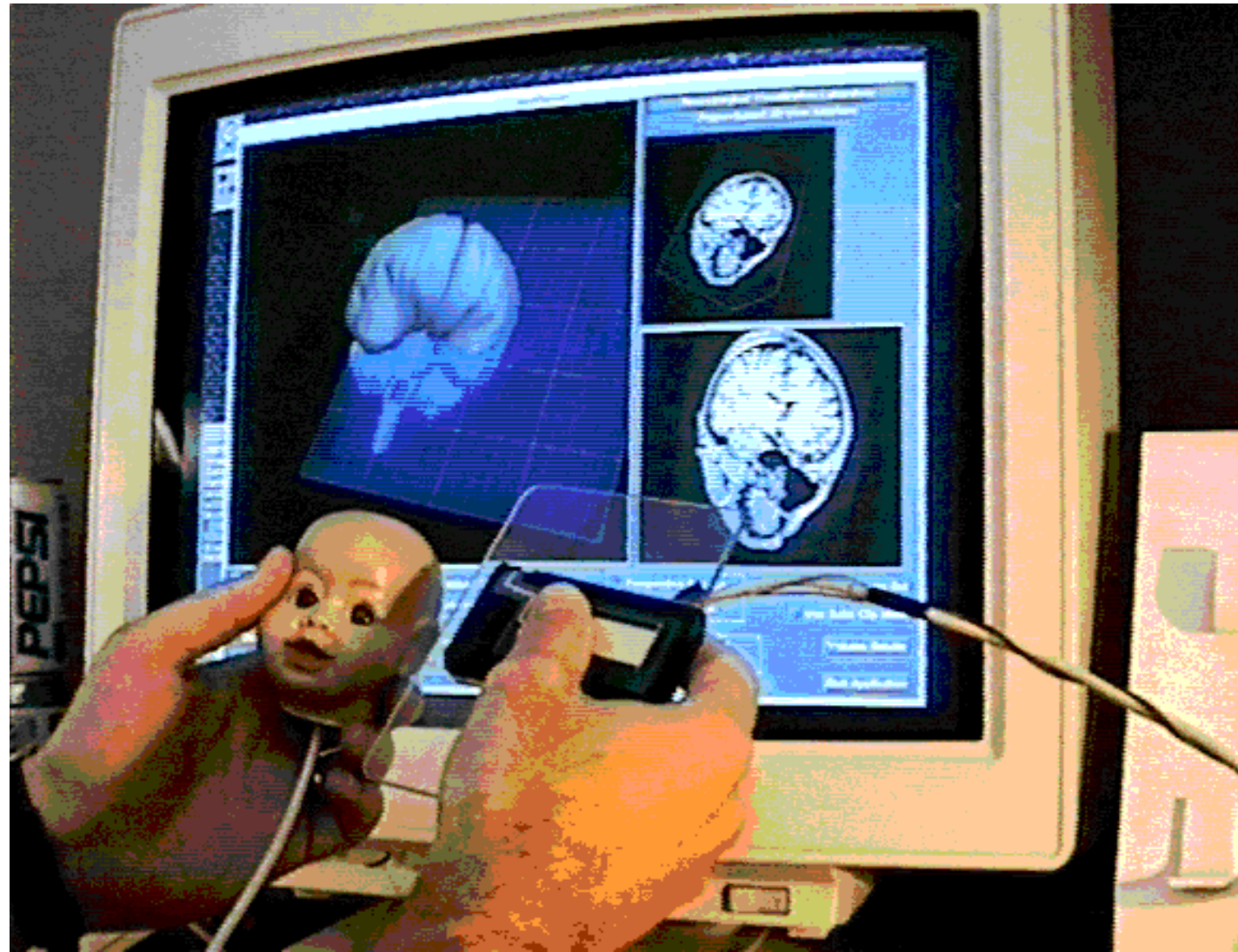

Hinckley et al. (1994)

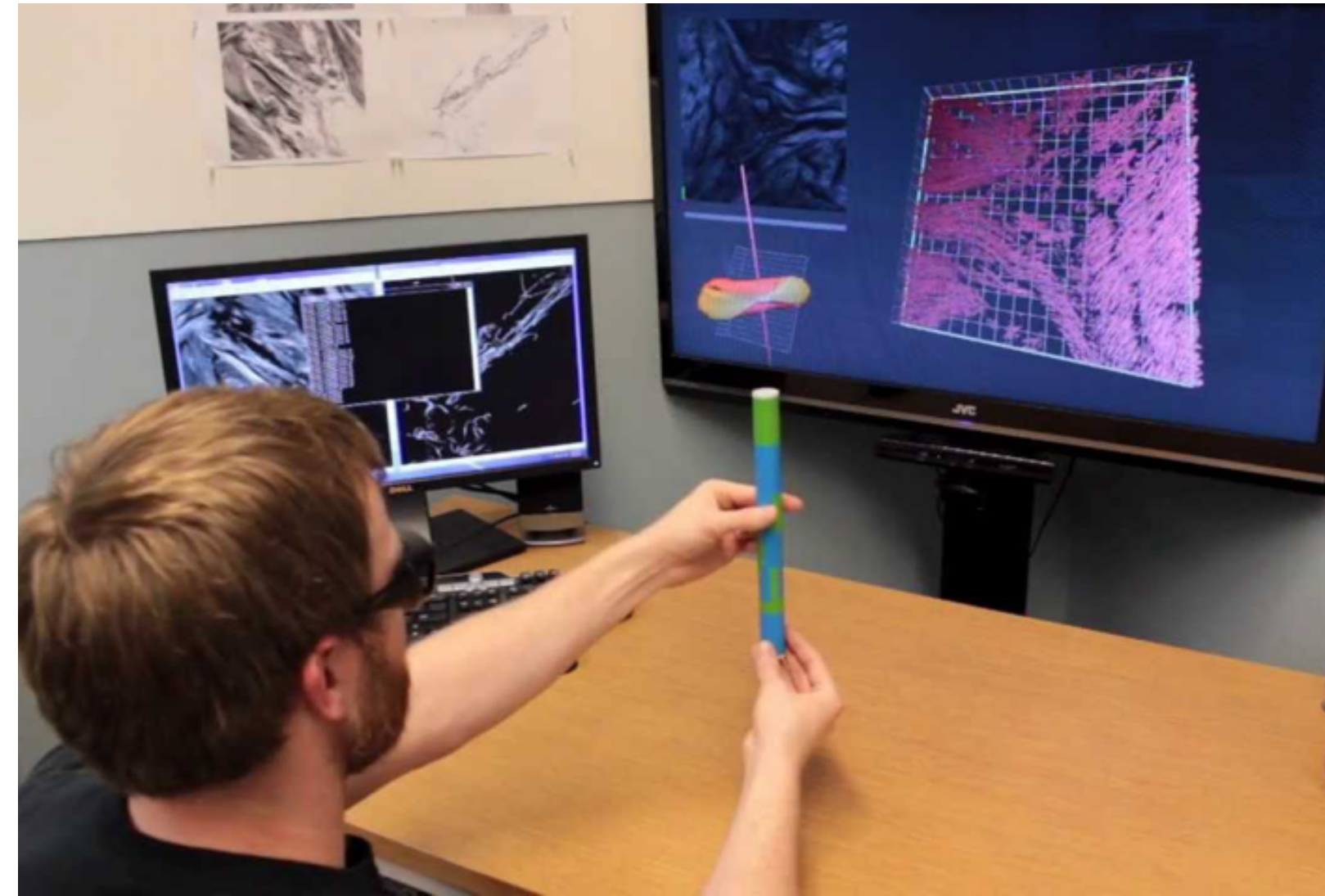

Jackson et al. (2013)

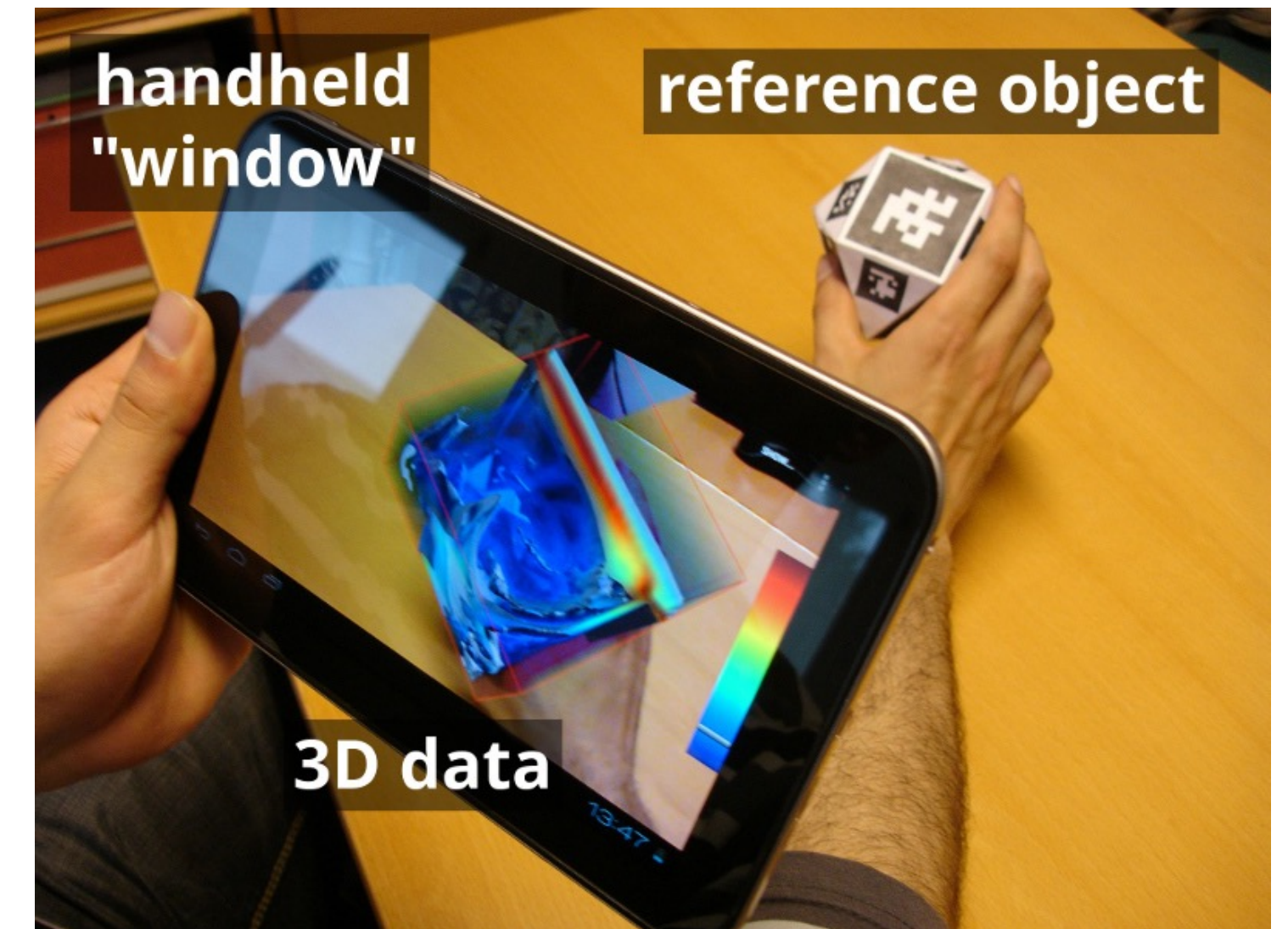

Issartel et al. (2014)

# Problem

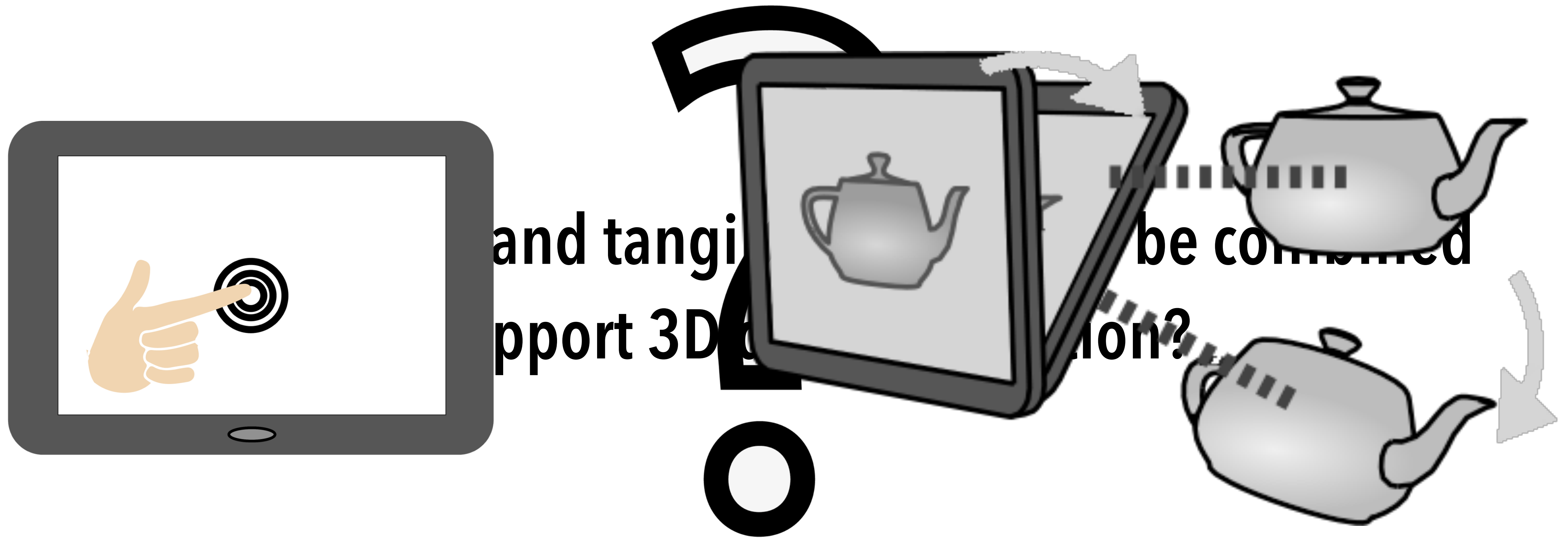



# Contributions

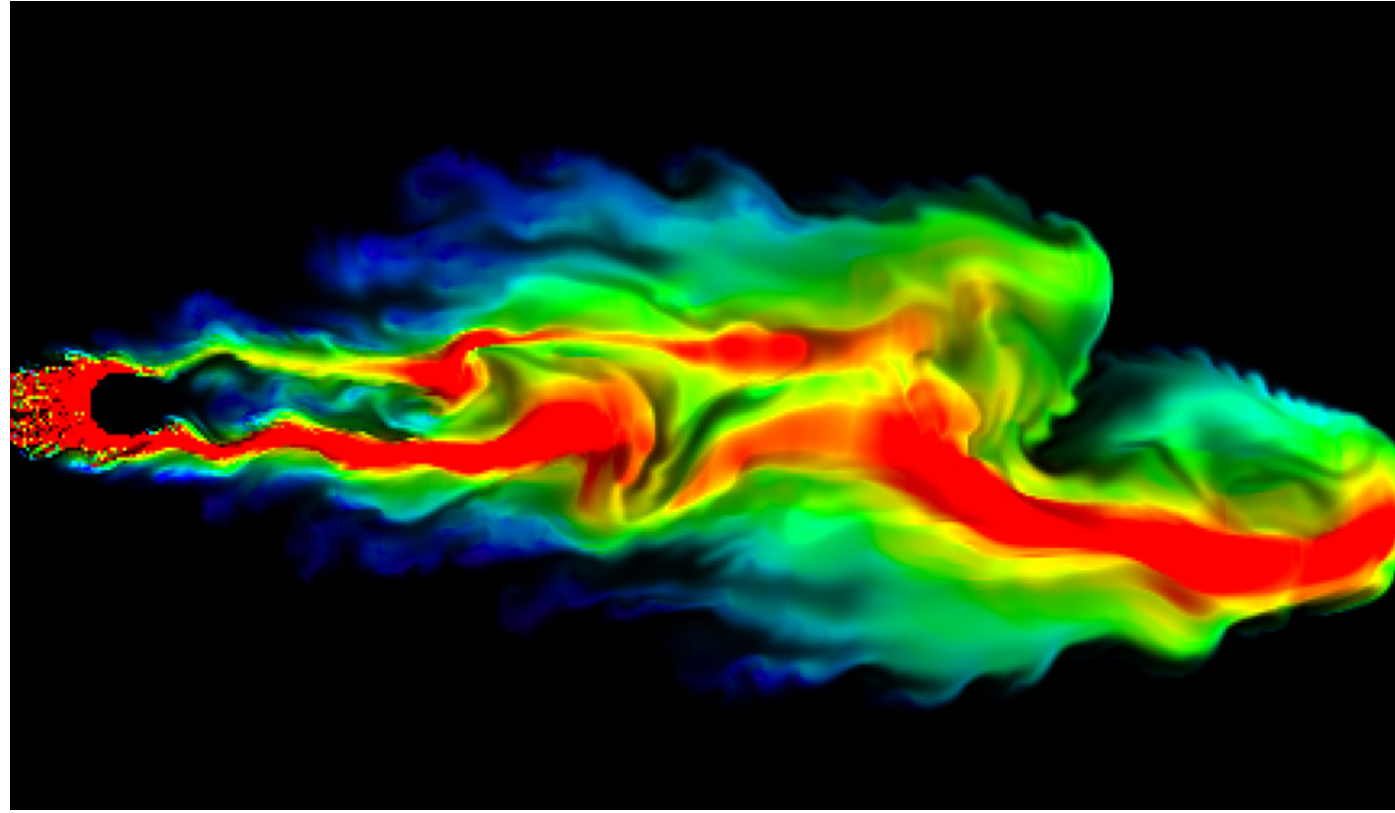

Tsigkari et al. (2012)

# Contributions

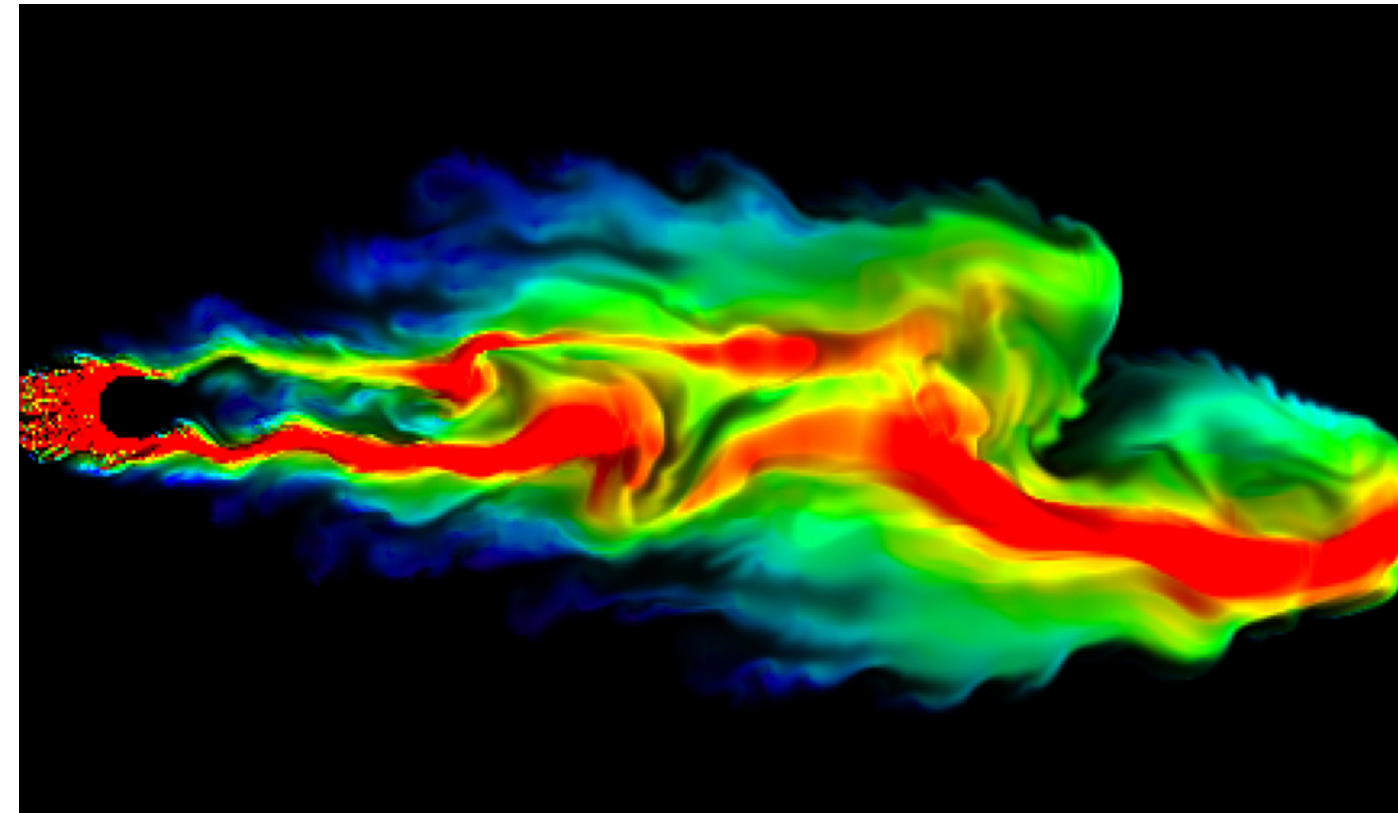

Tsigkari et al. (2012)

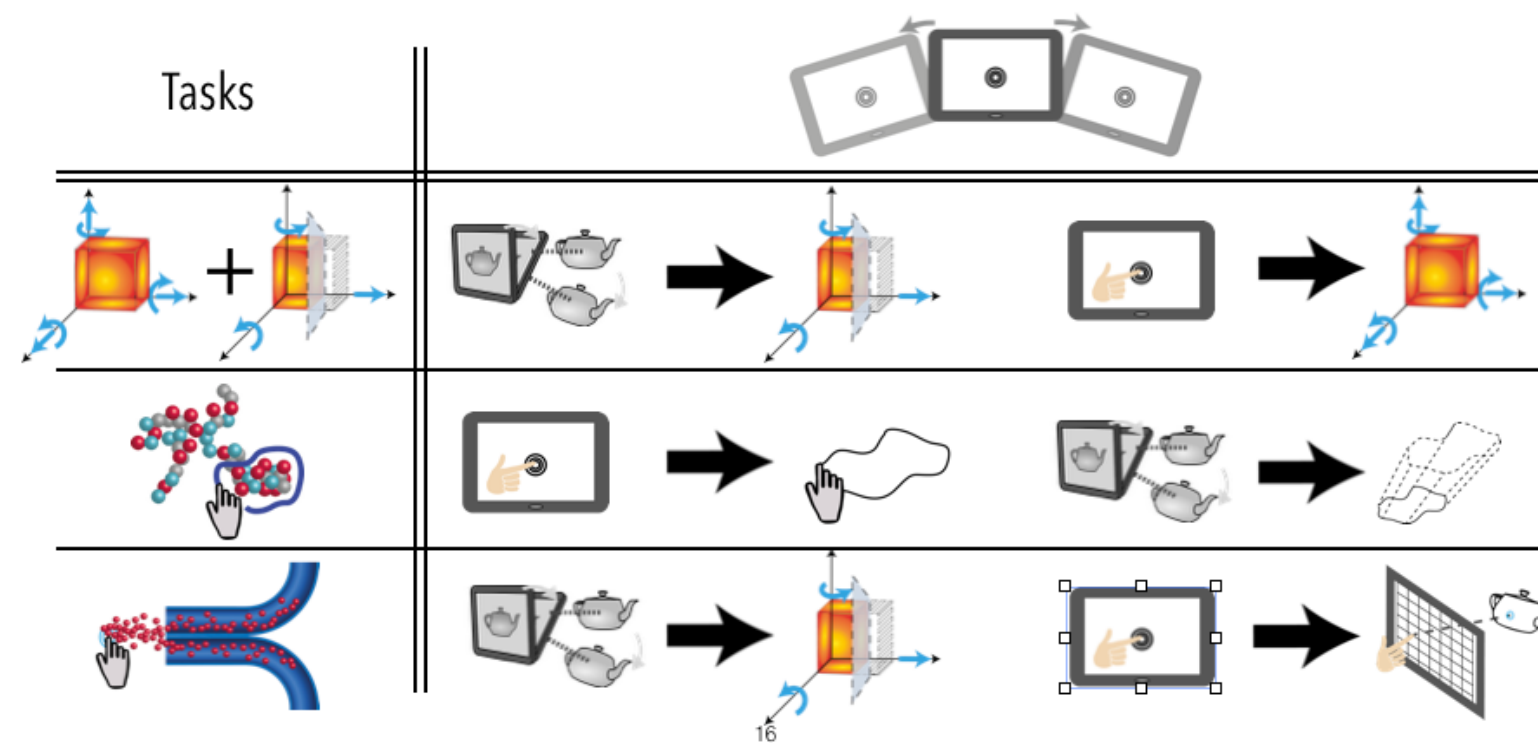
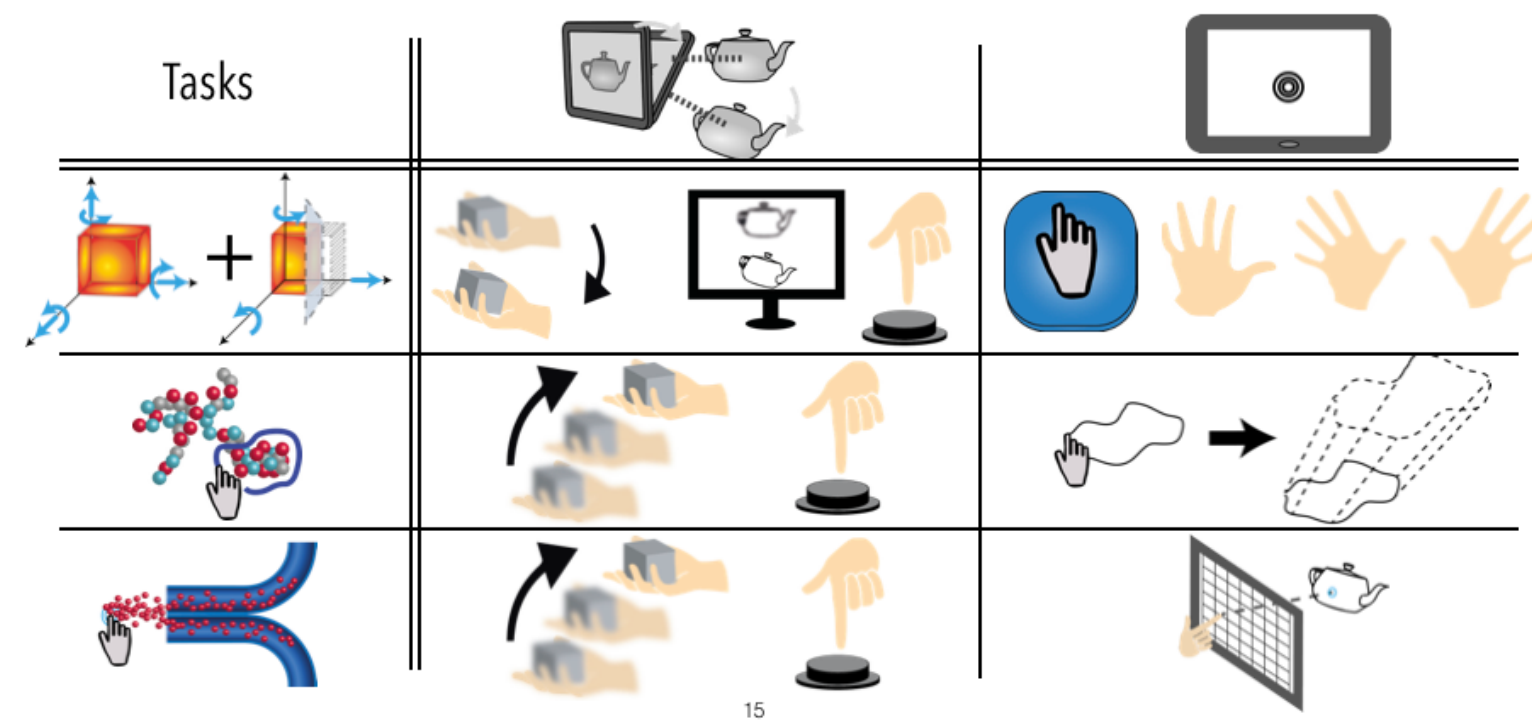

# Contributions

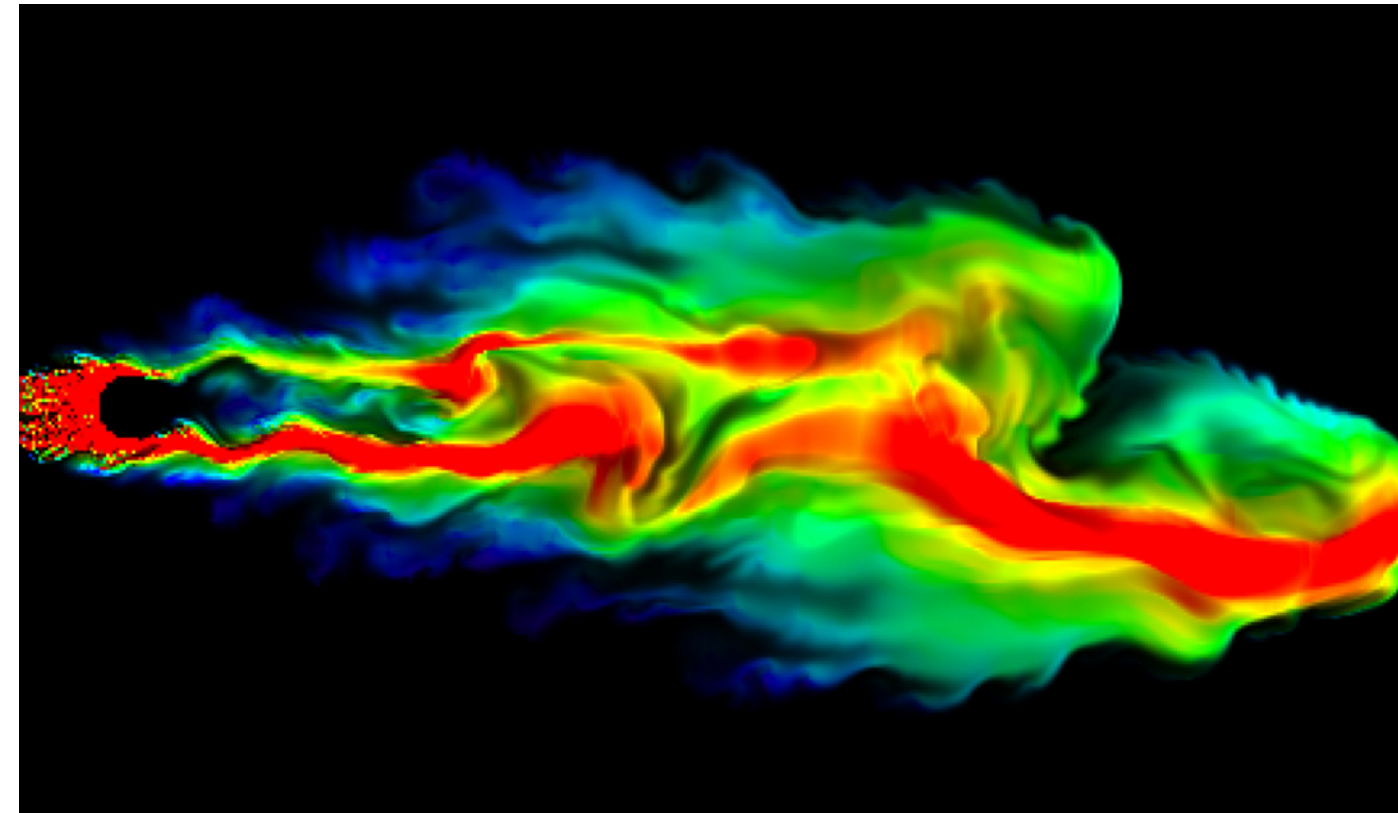

Tsigkari et al. (2012)

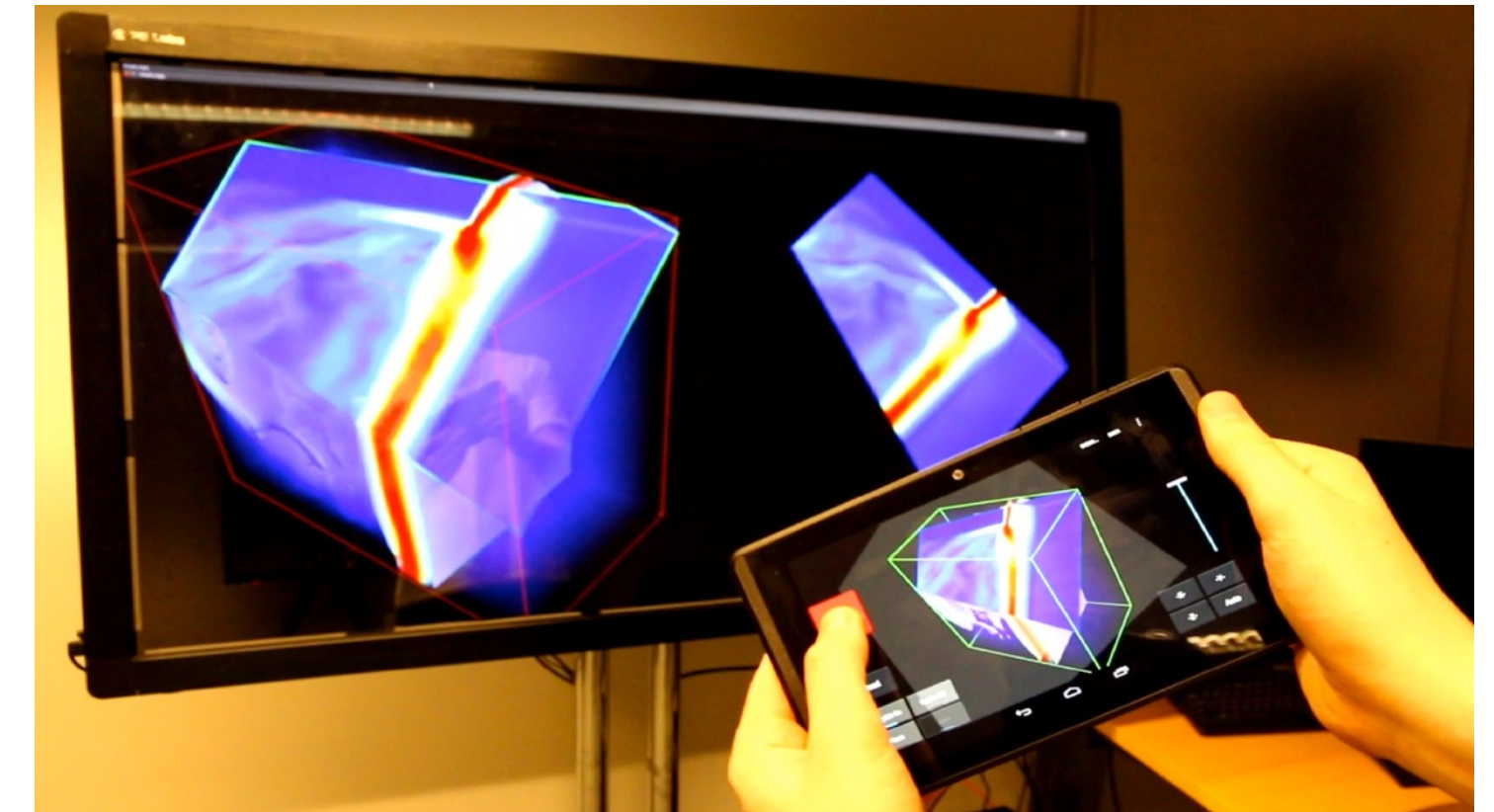
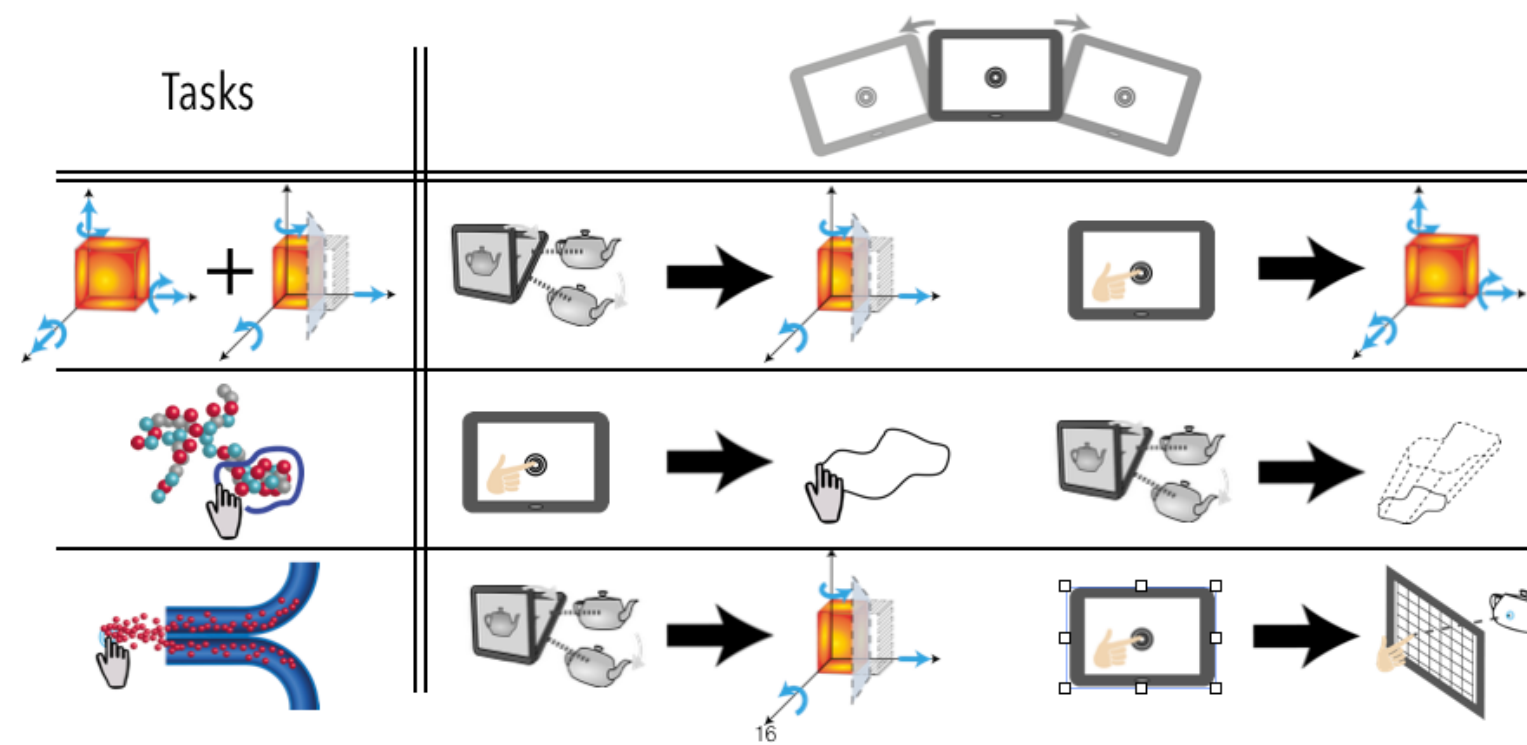
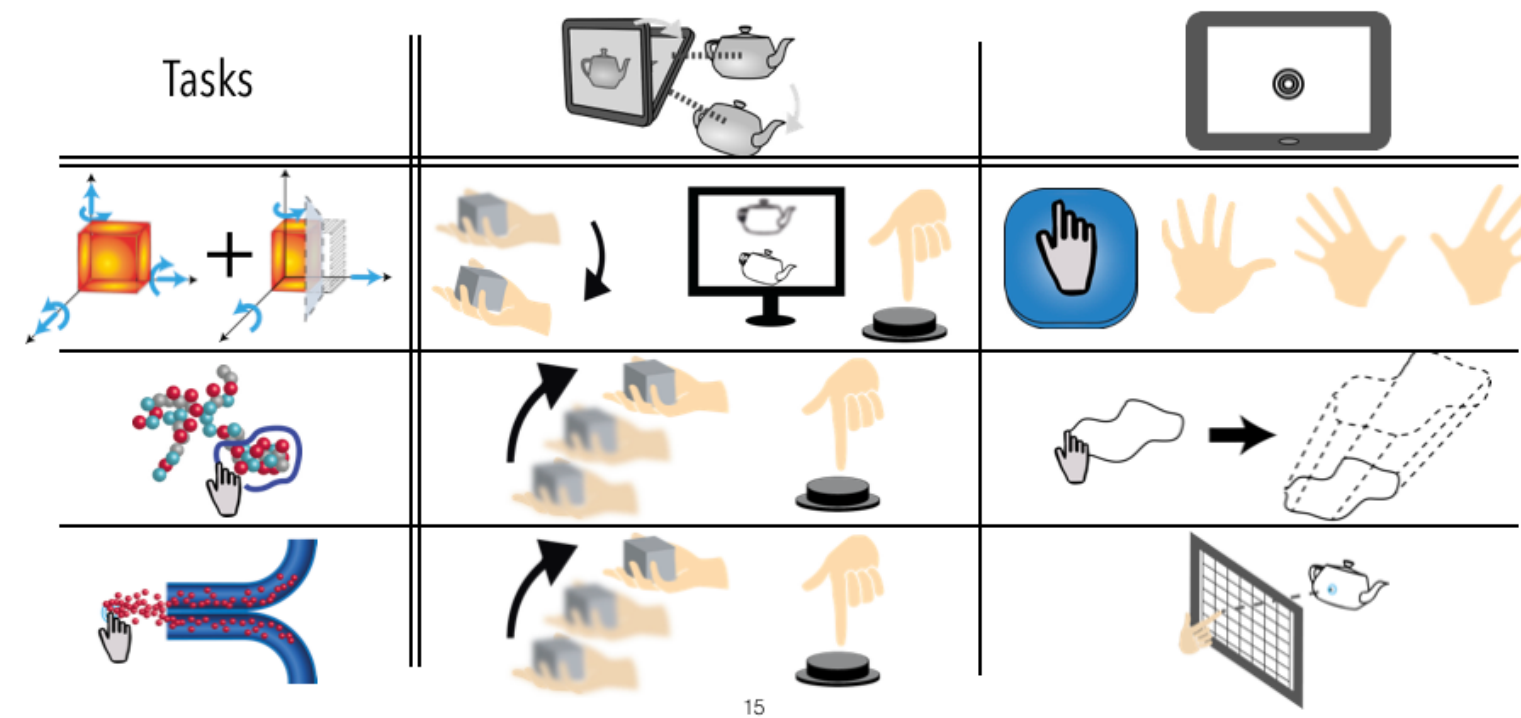

**Contribution #1:**  
**Understanding the needs of fluid dynamic experts**

# Preliminary study: understanding experts needs

- Field study with experts
- Five fluid dynamic researchers
- Observations and video-recordings
- Semi-structured interviews

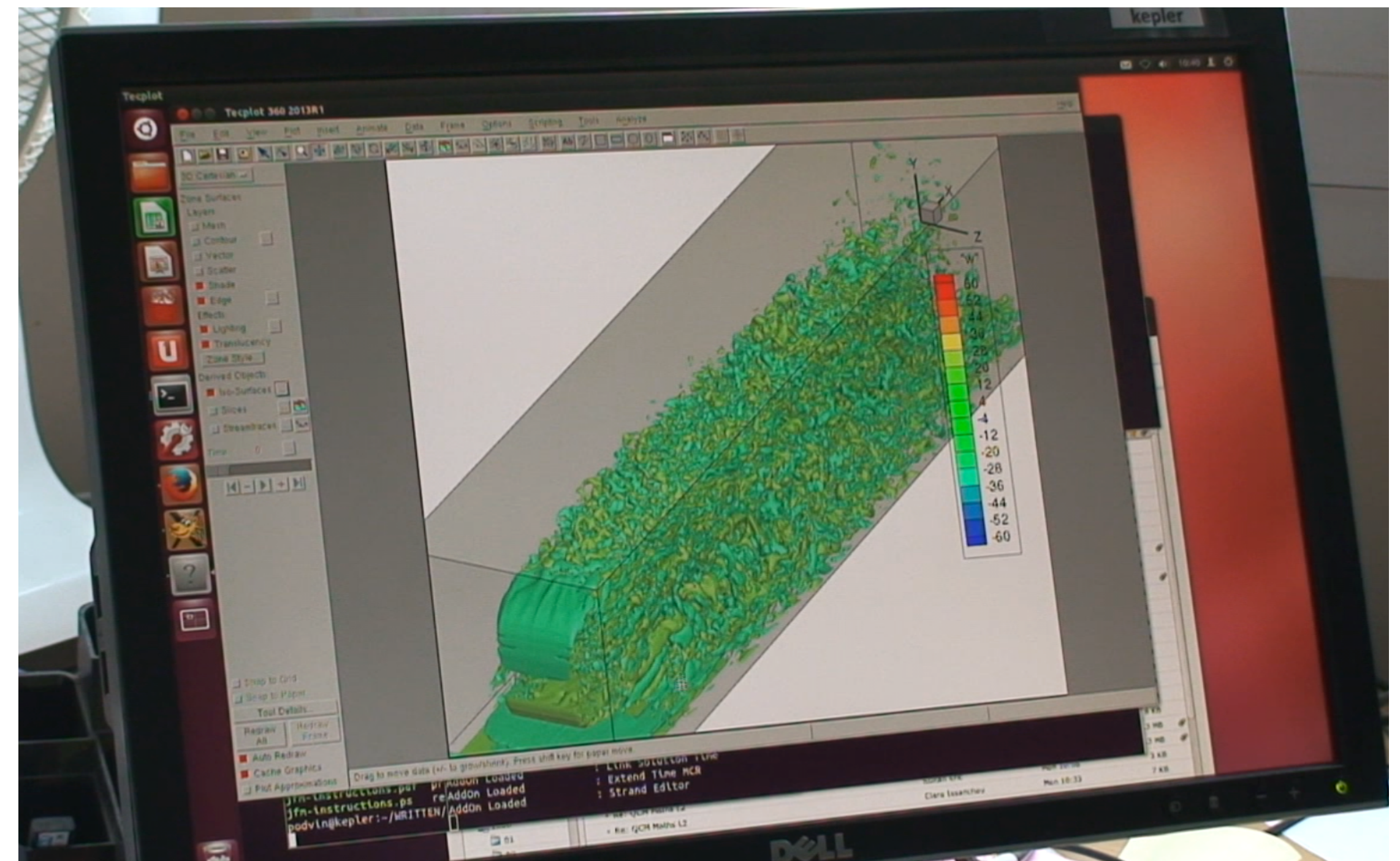

# Preliminary study results

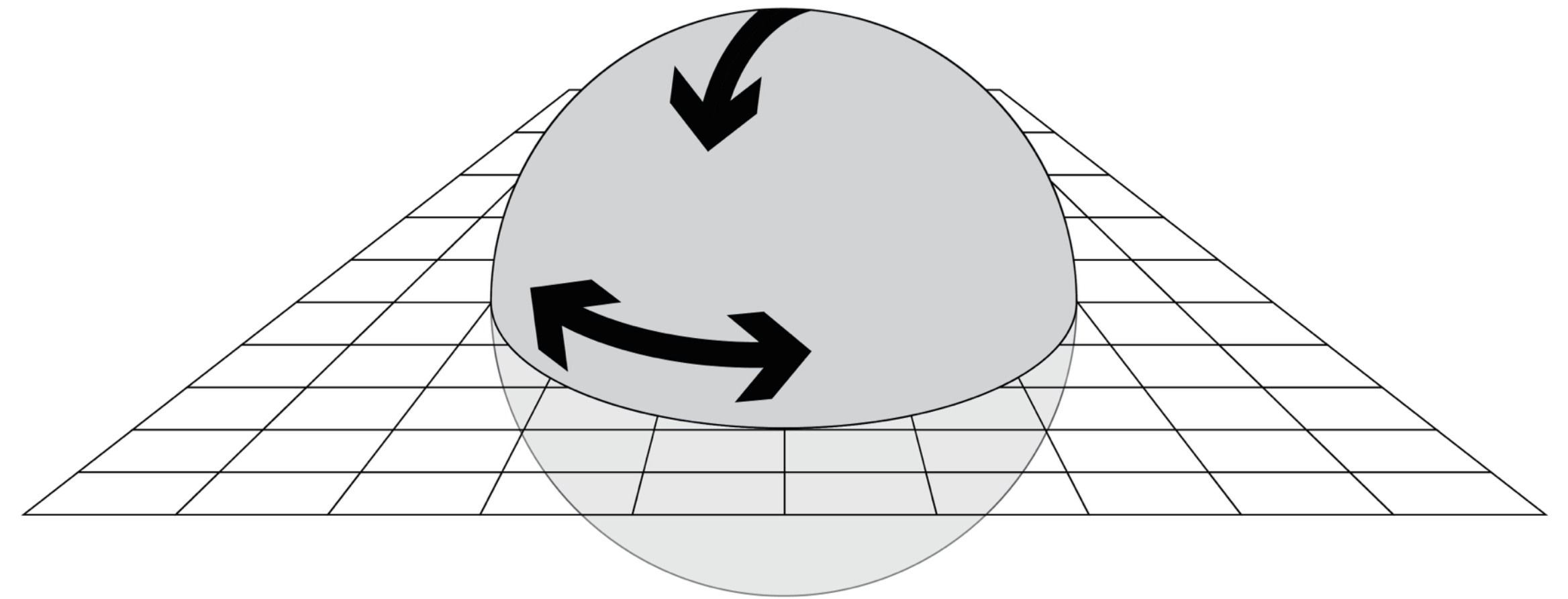
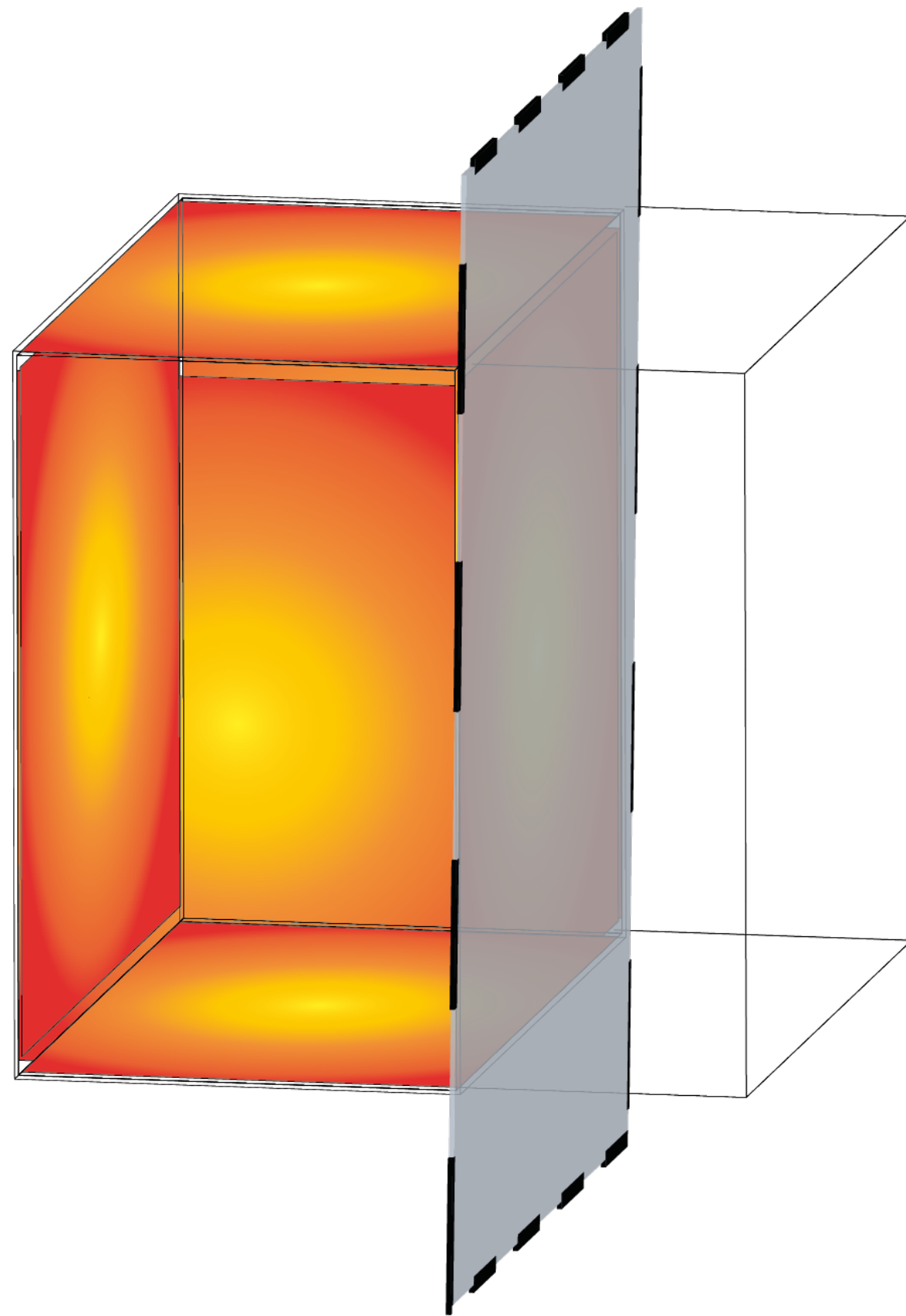

# Preliminary study results

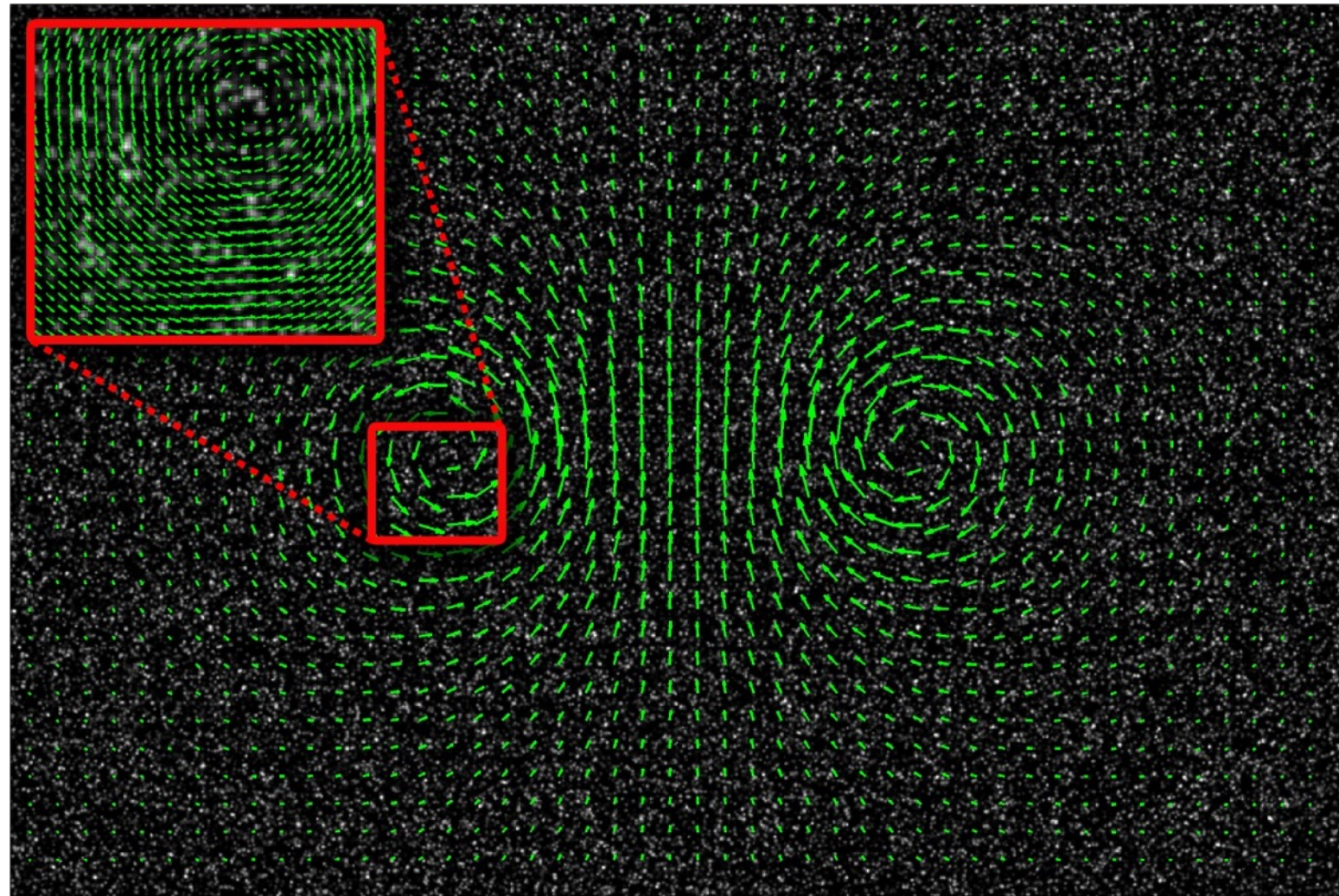

PIVlab multipass ©Willa

Creative Commons Attribution-Share Alike 3.0 Unported

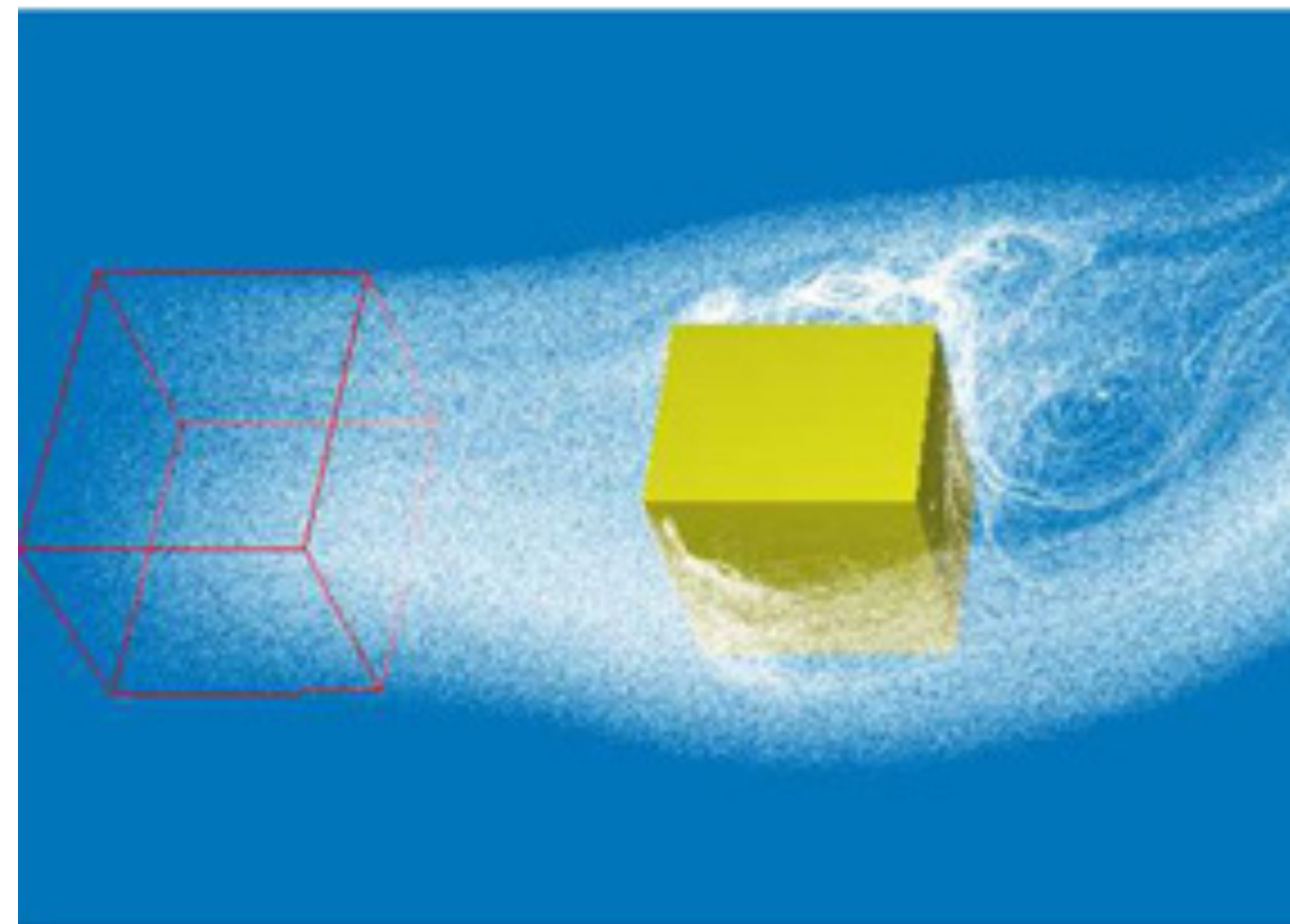

Kruger et al. (2005)

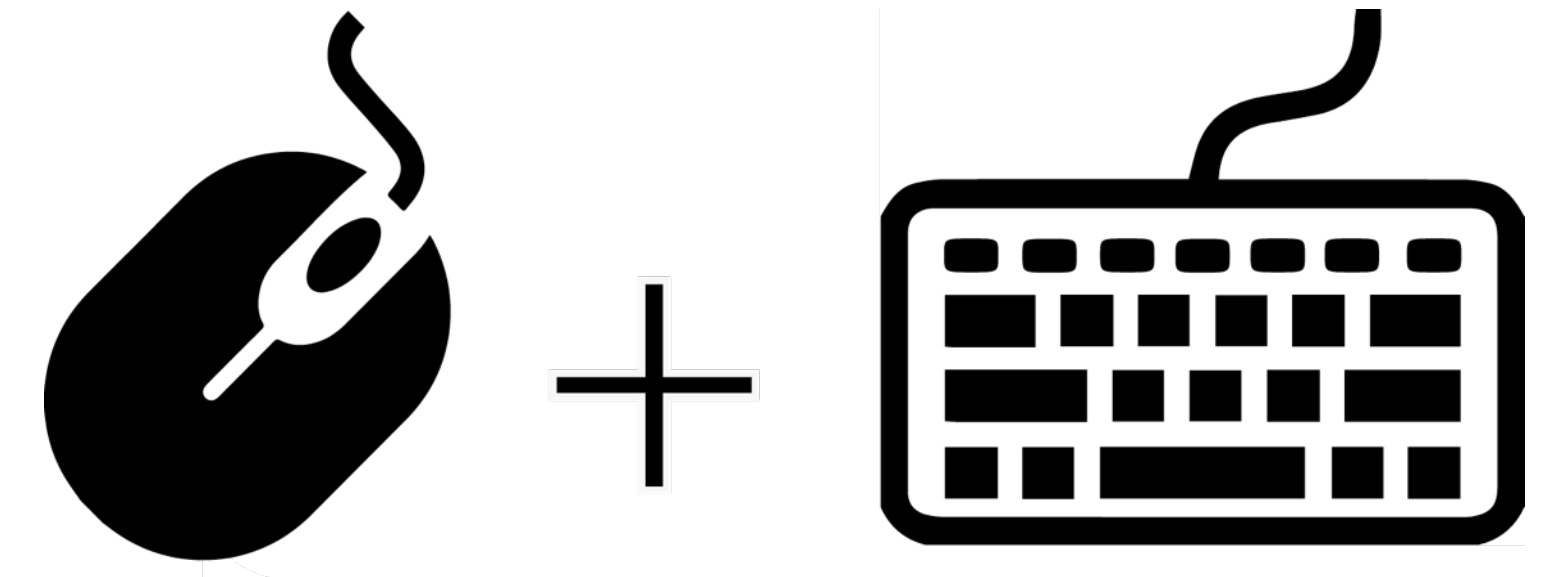

# Interaction Tasks in Spatial 3D data

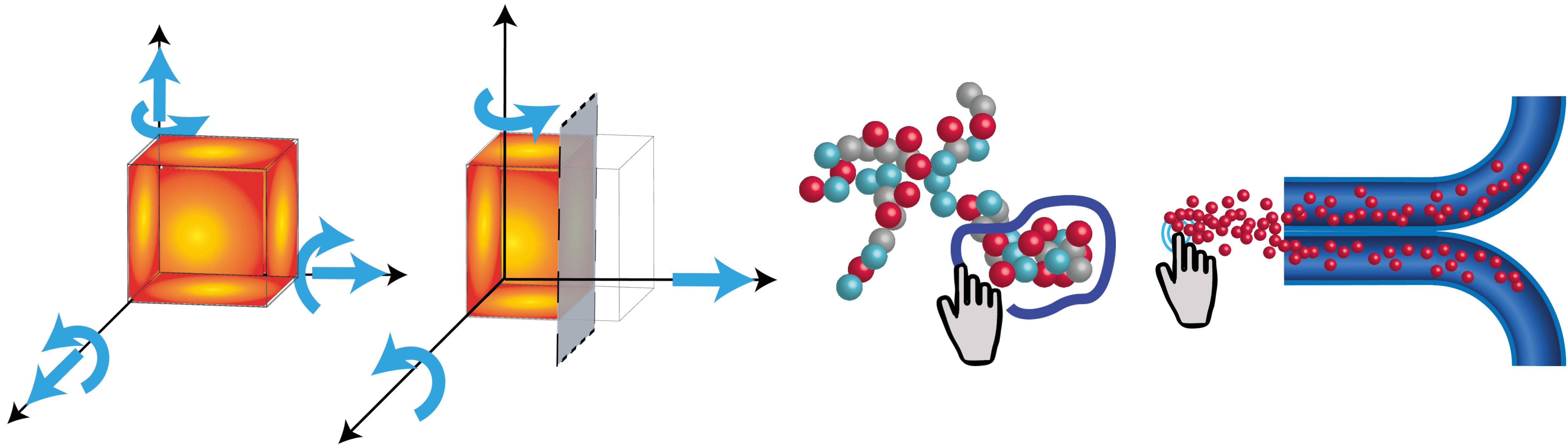



# **Contribution #2: Design space exploration**

# Examples

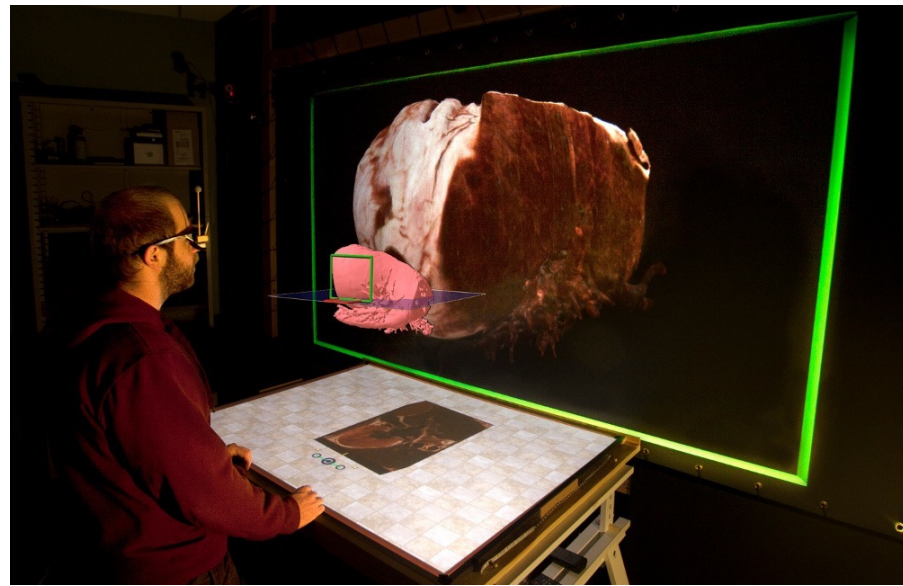

Coffey et al. (2012)

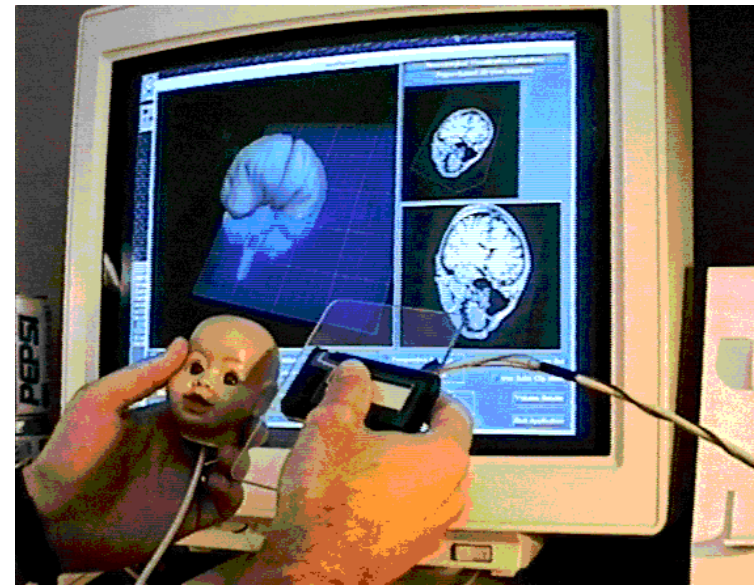

Hinckley et al. (1994)

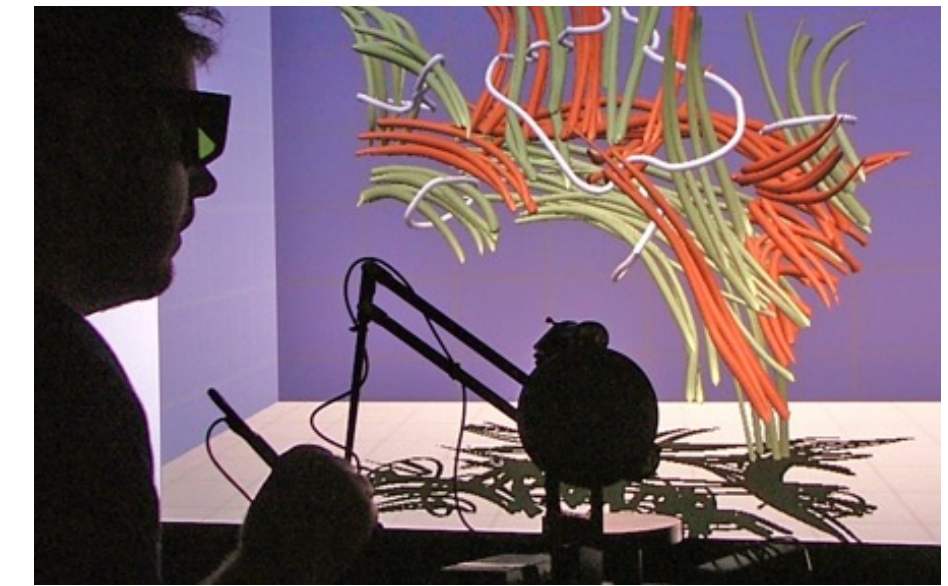

Keefe (2010)

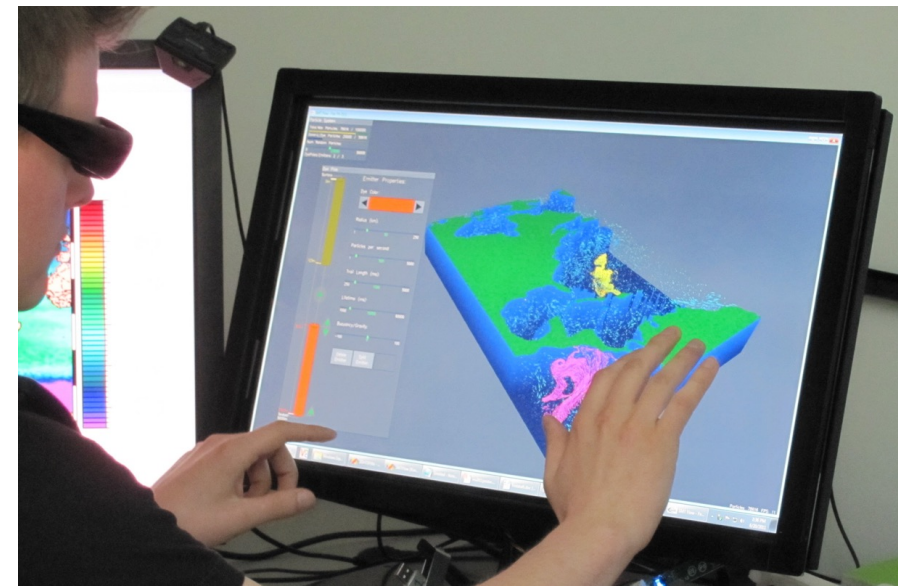

Butkiewicz & Ware (2012)

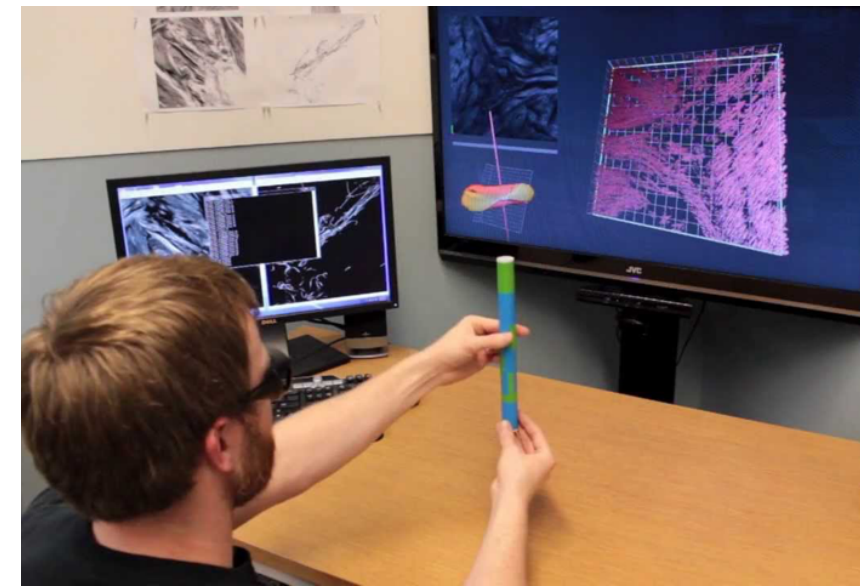

Jackson et al. (2013)



Schkolne et al. (2012)



Jackson et al. (2012)

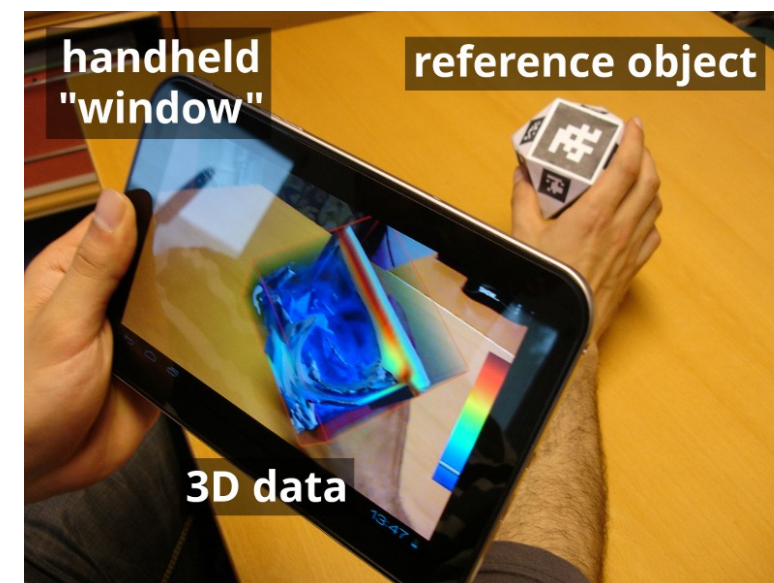

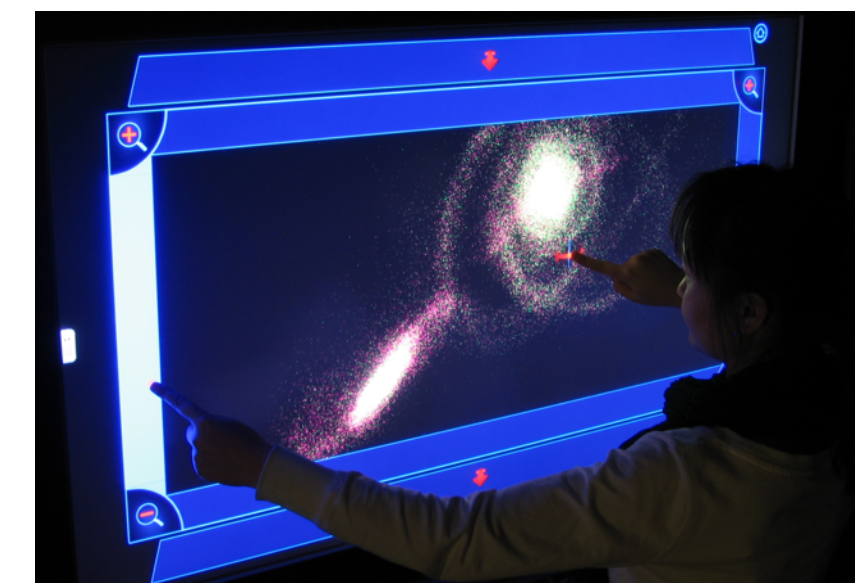

Issartel et al. (2014)

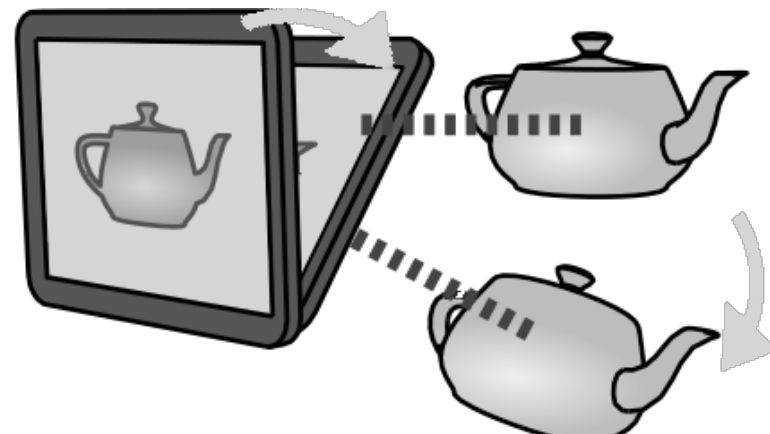
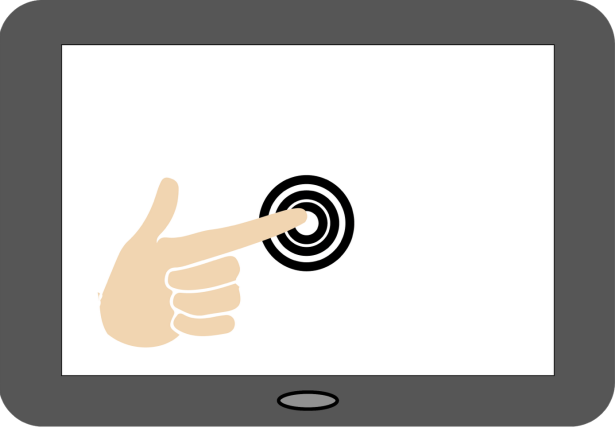
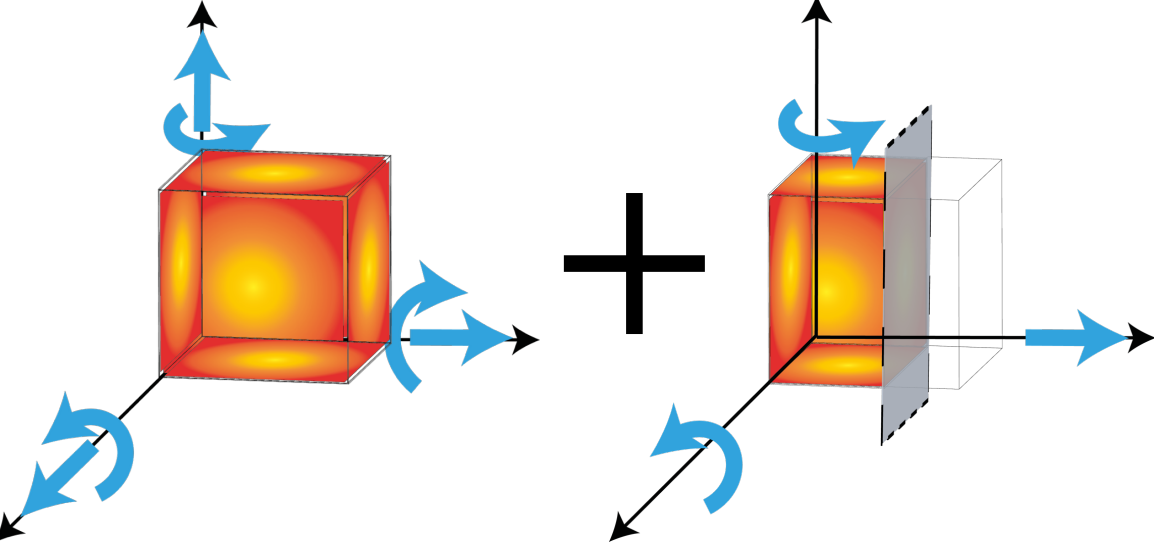

Yu et al. (2014)

# Design Space Exploration: tactile-only and tangible-only settings

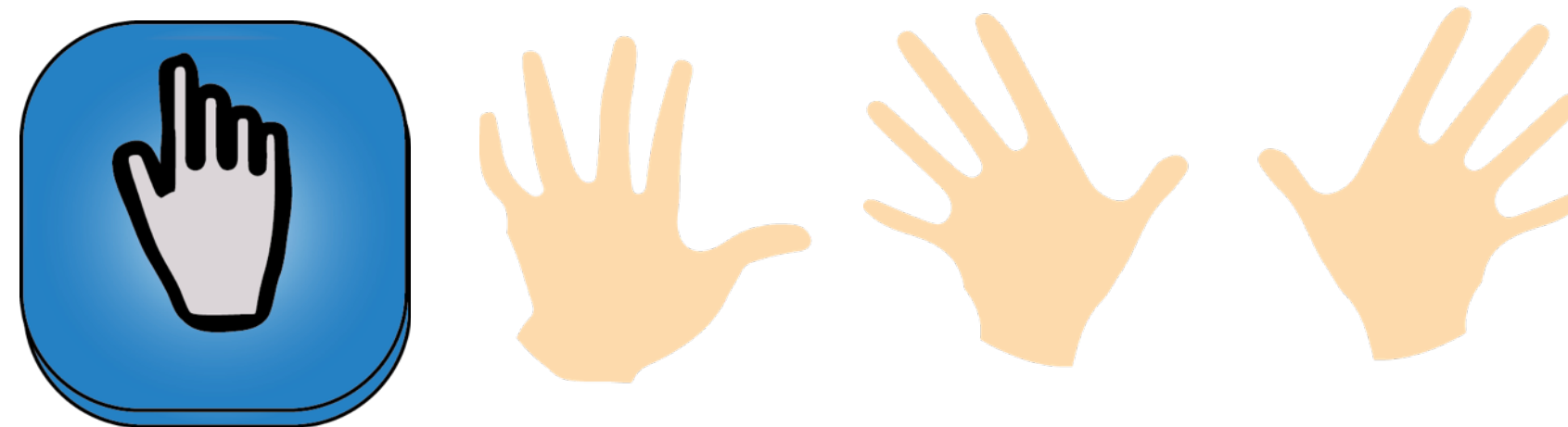
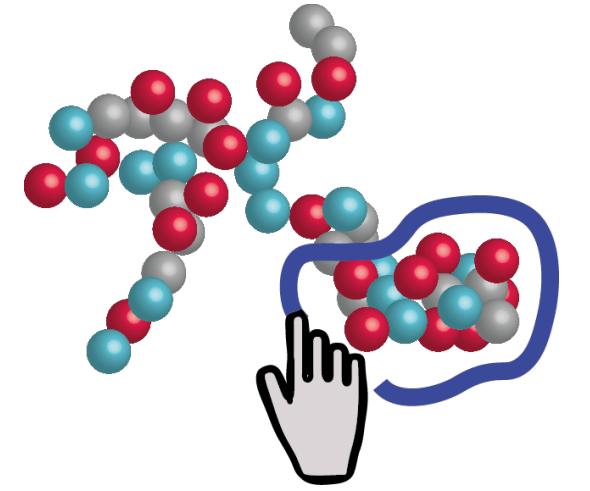
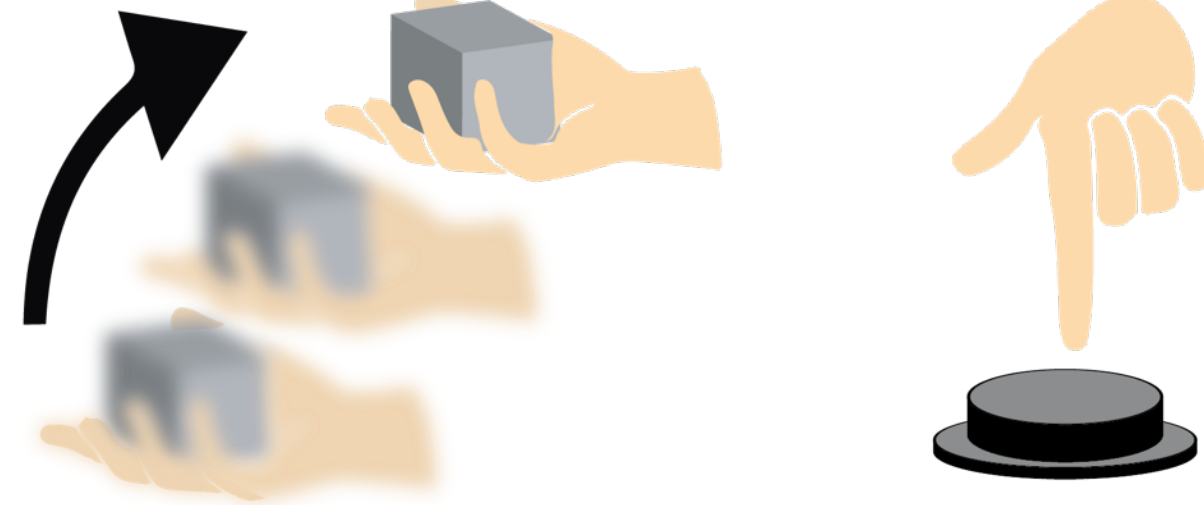
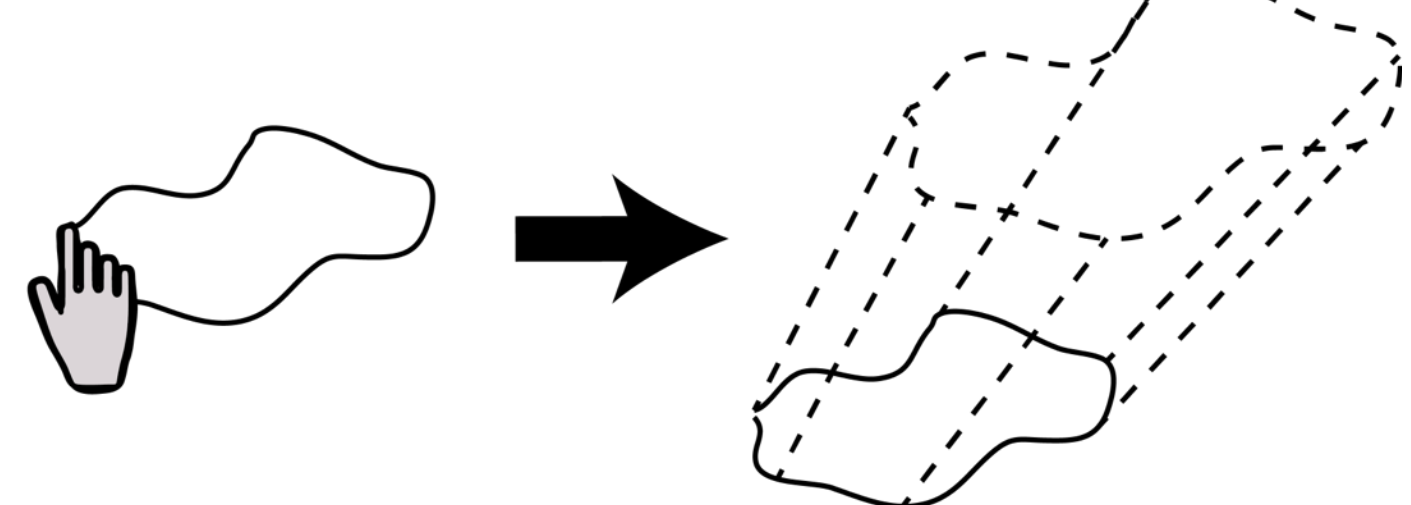
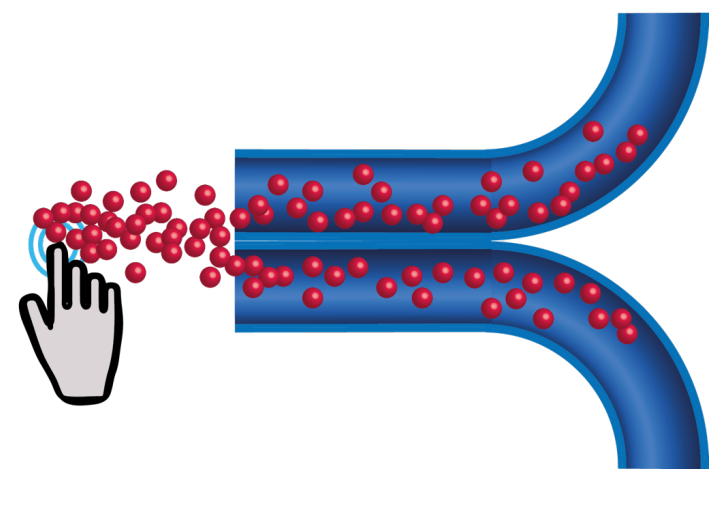
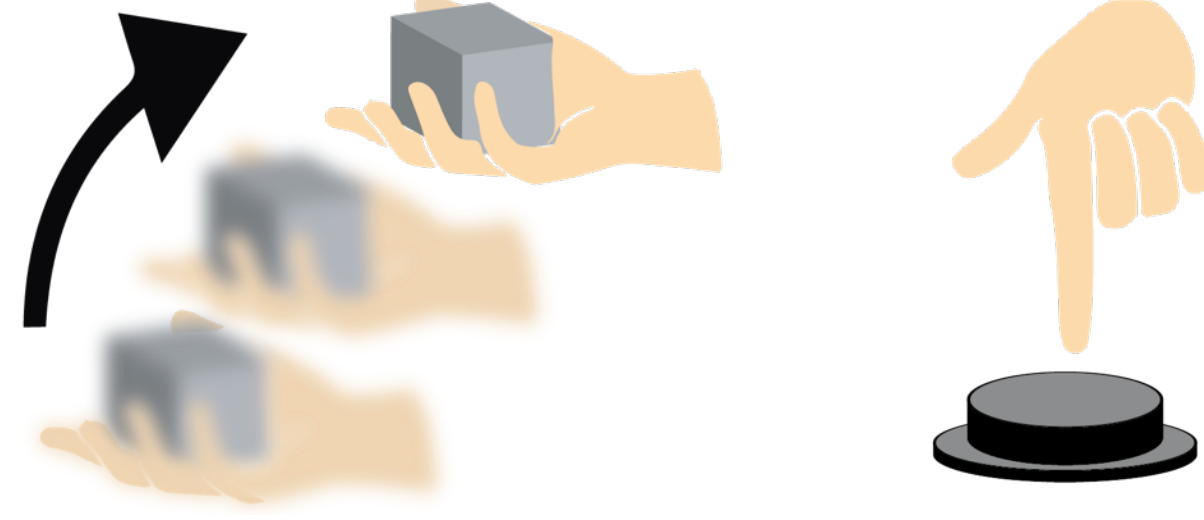
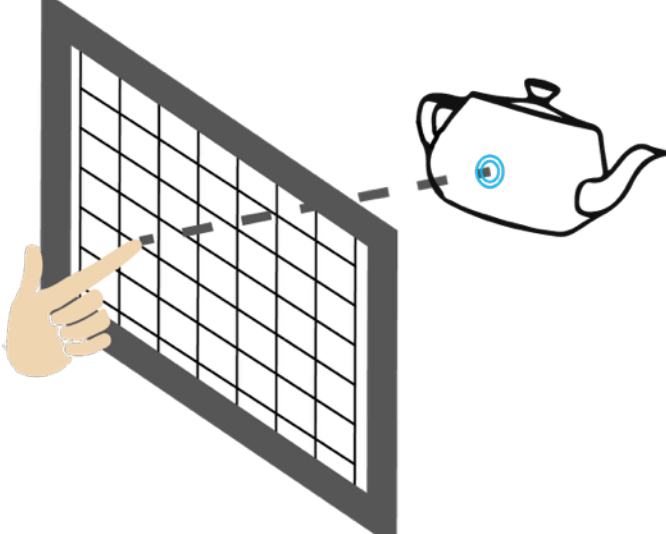
Tasks		
		
		
		

# Design Space Exploration: Hybrid interaction

Tasks

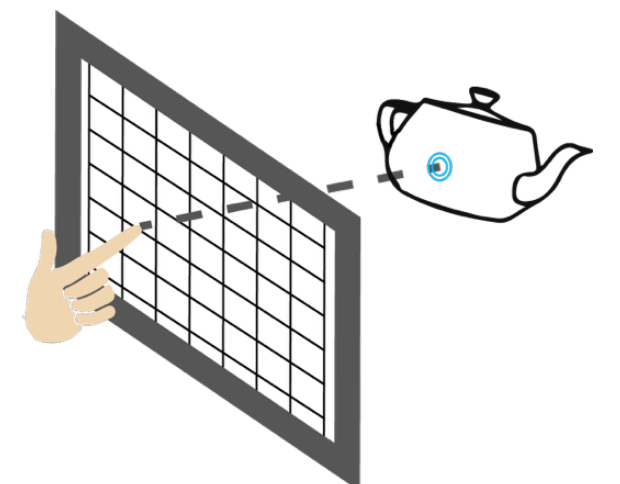
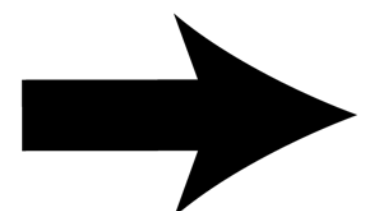
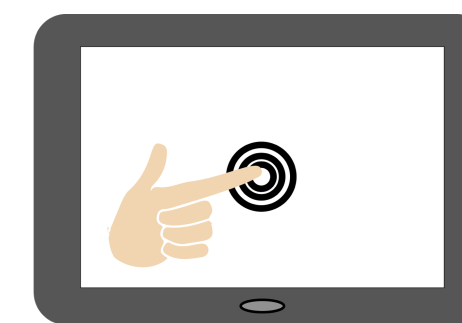
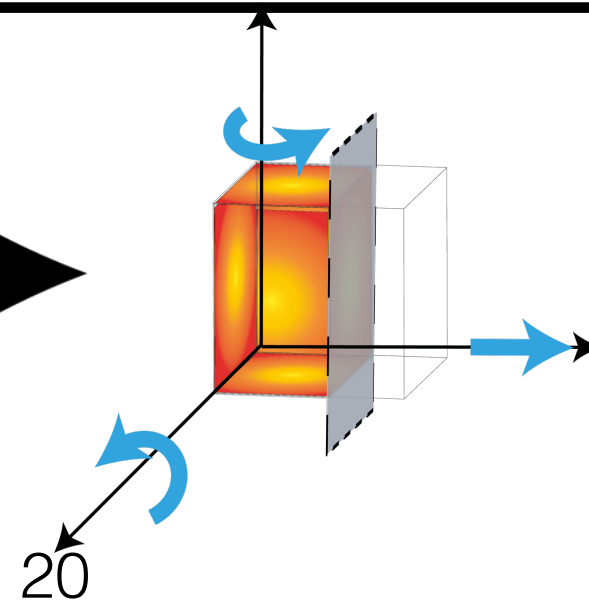
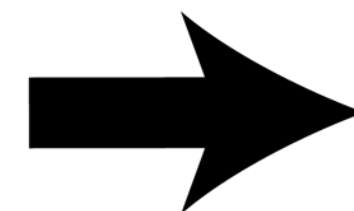
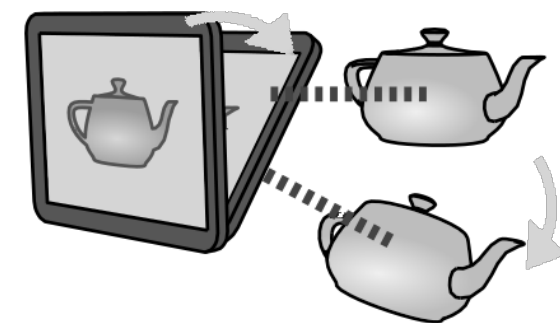
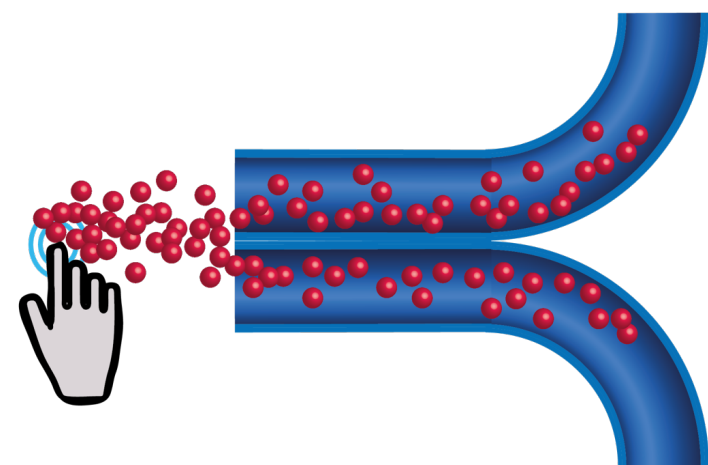
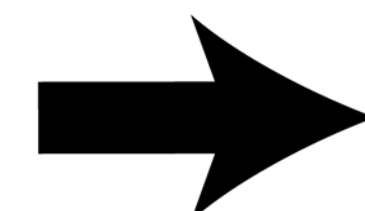
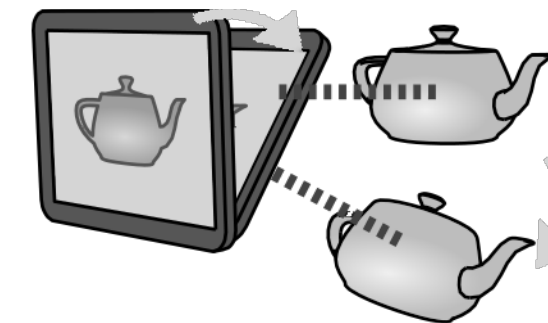
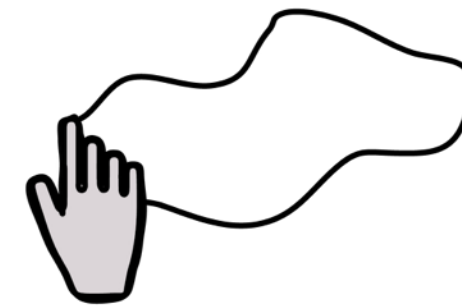
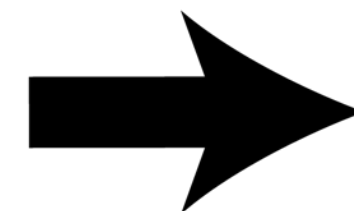
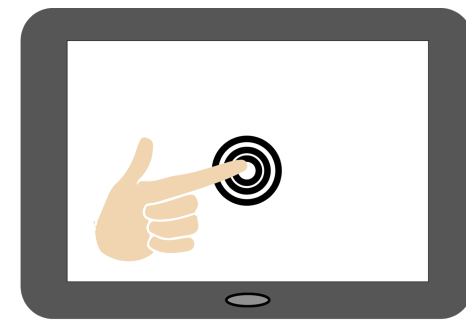
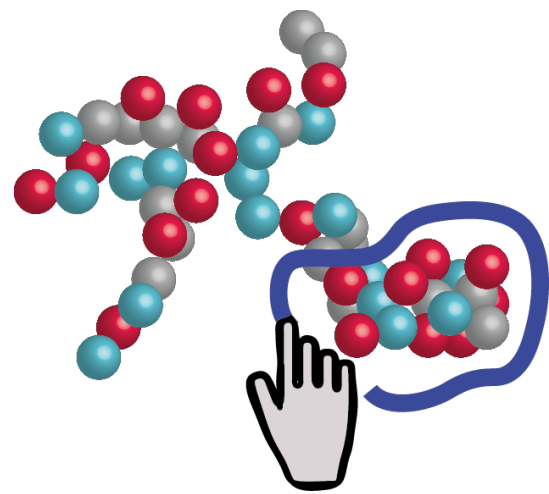
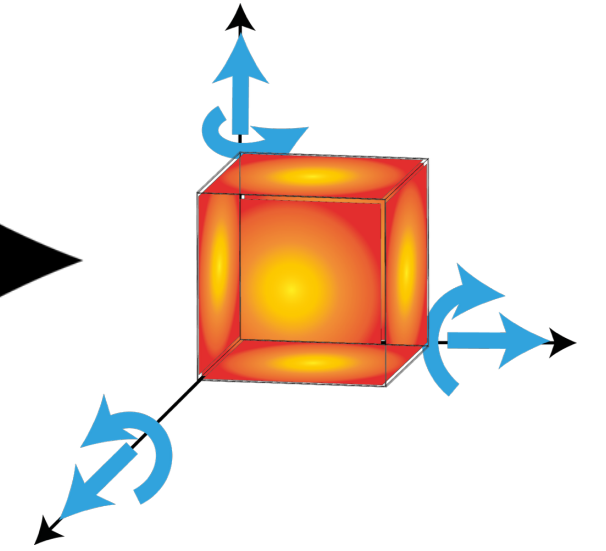
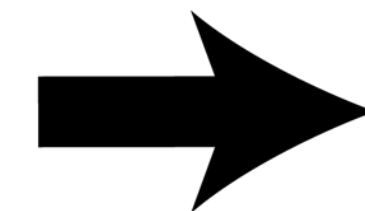
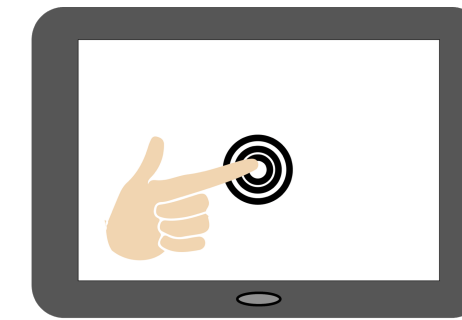
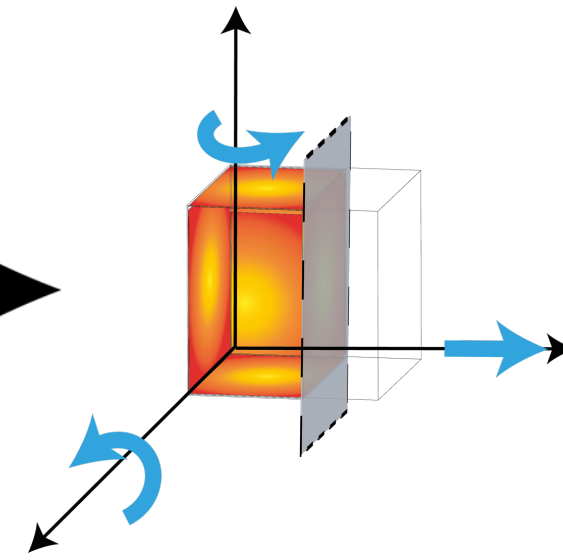
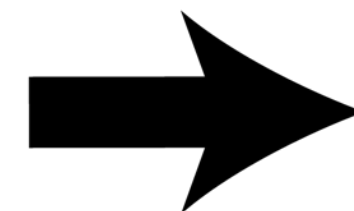
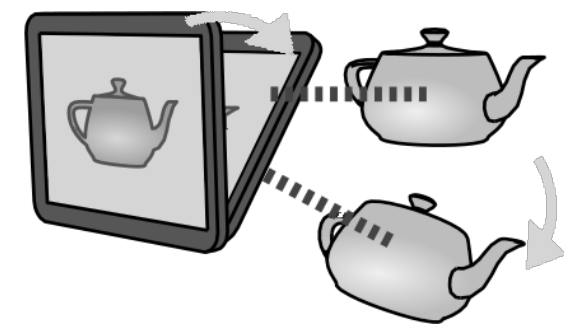
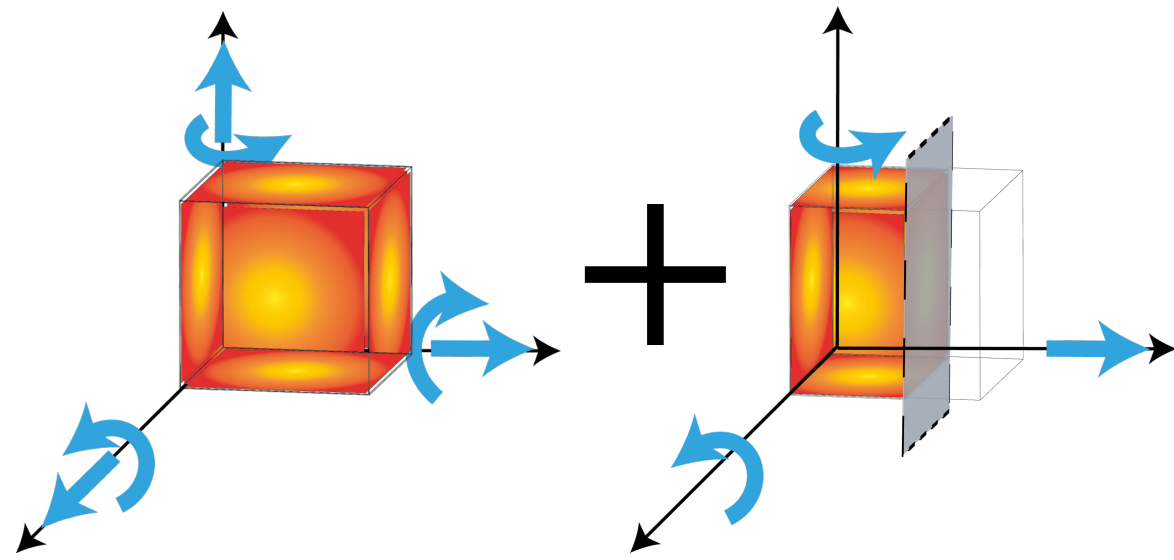
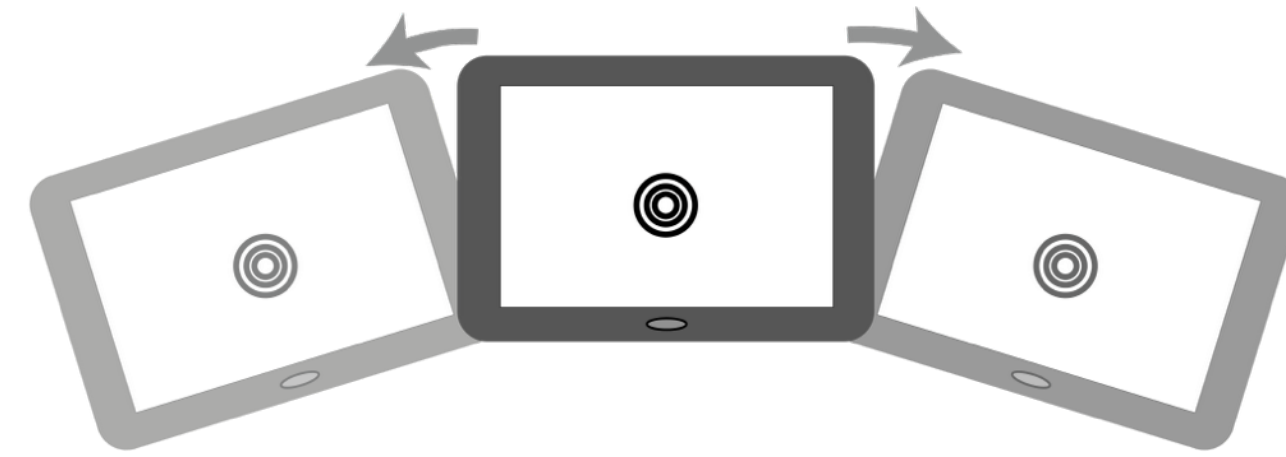

**Contribution #3:**  
**Hybrid interaction prototype and user study**

# Prototype



# Prototype

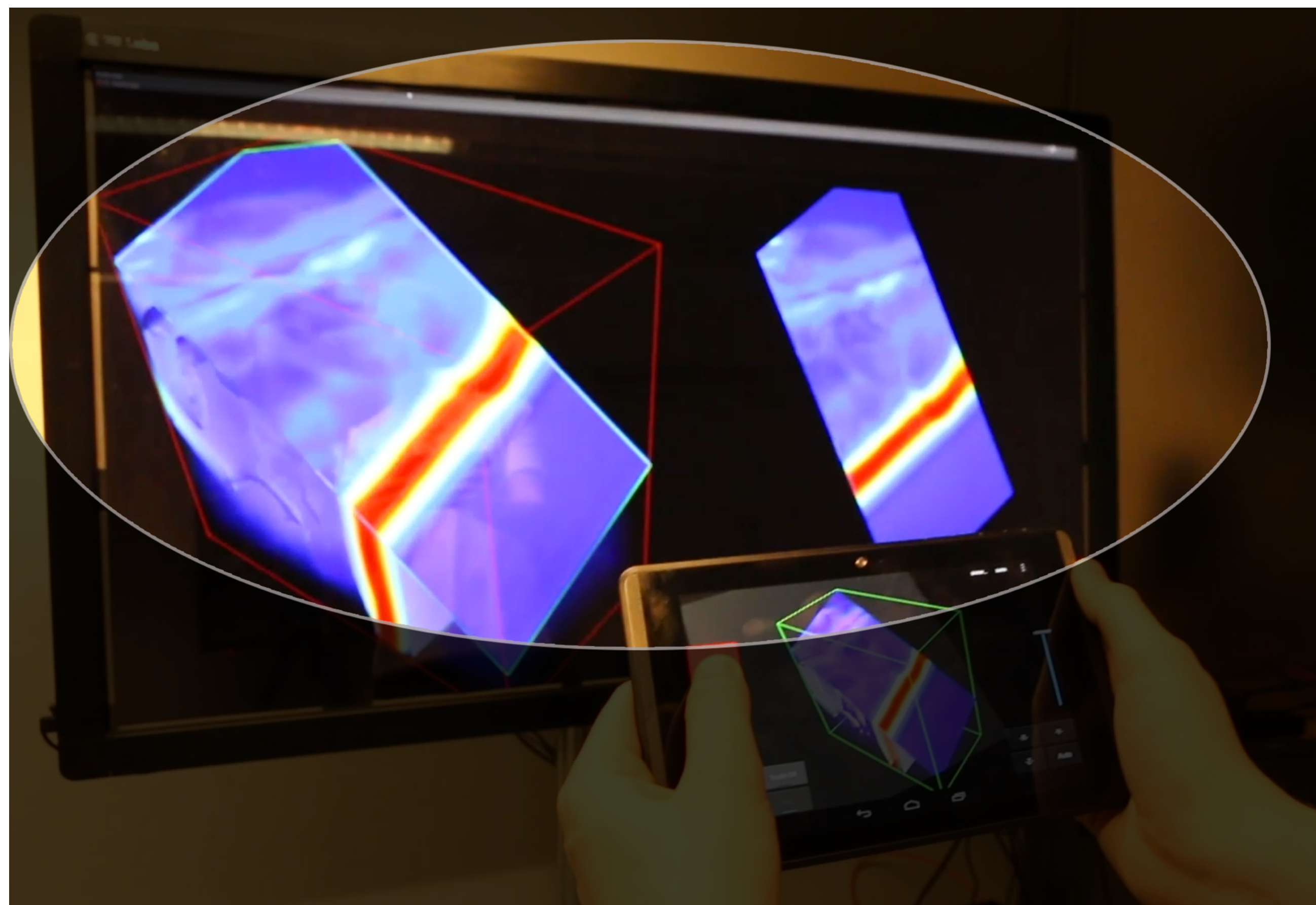

# Prototype

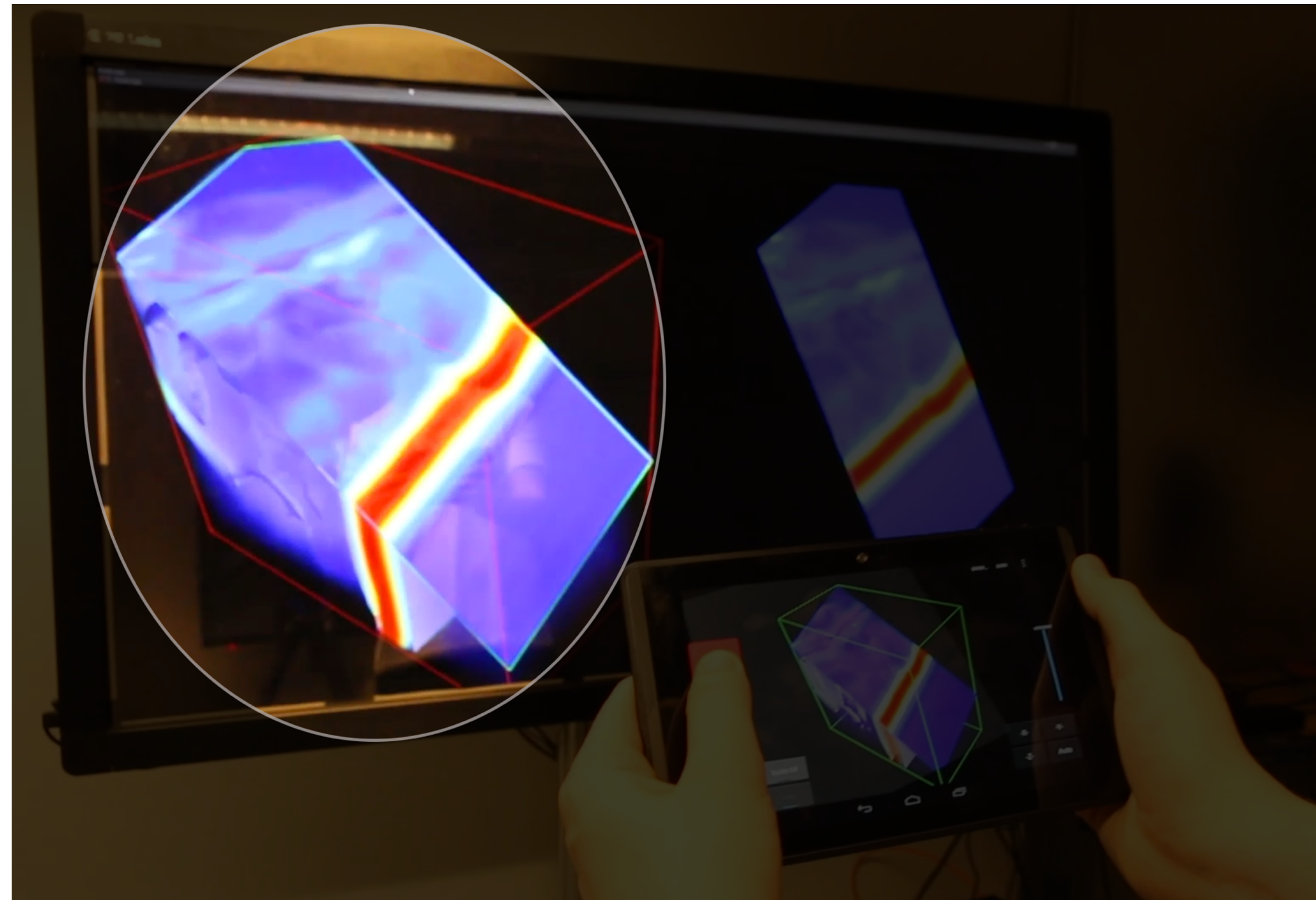



# Prototype

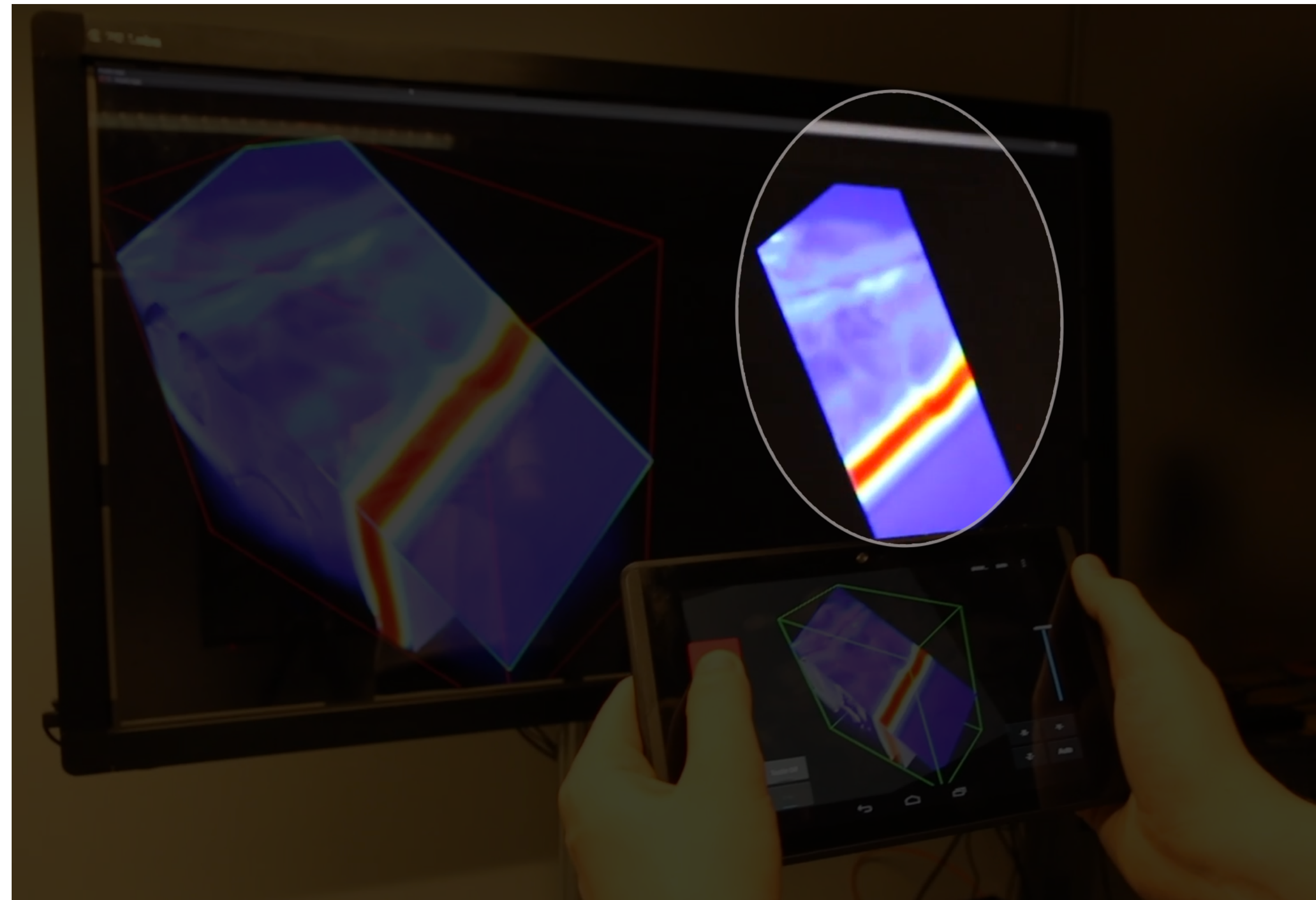

# User Interface

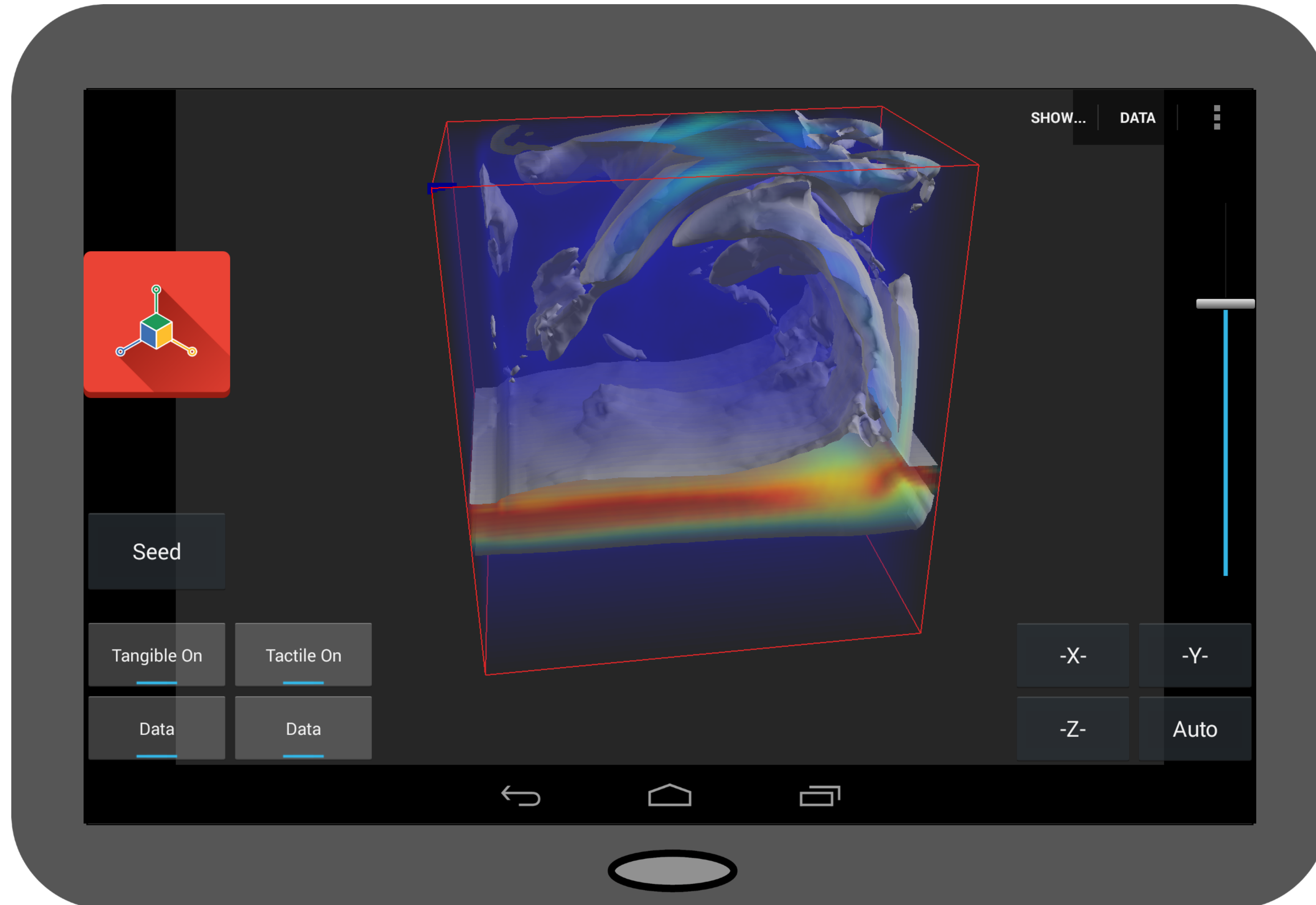

# User Interface

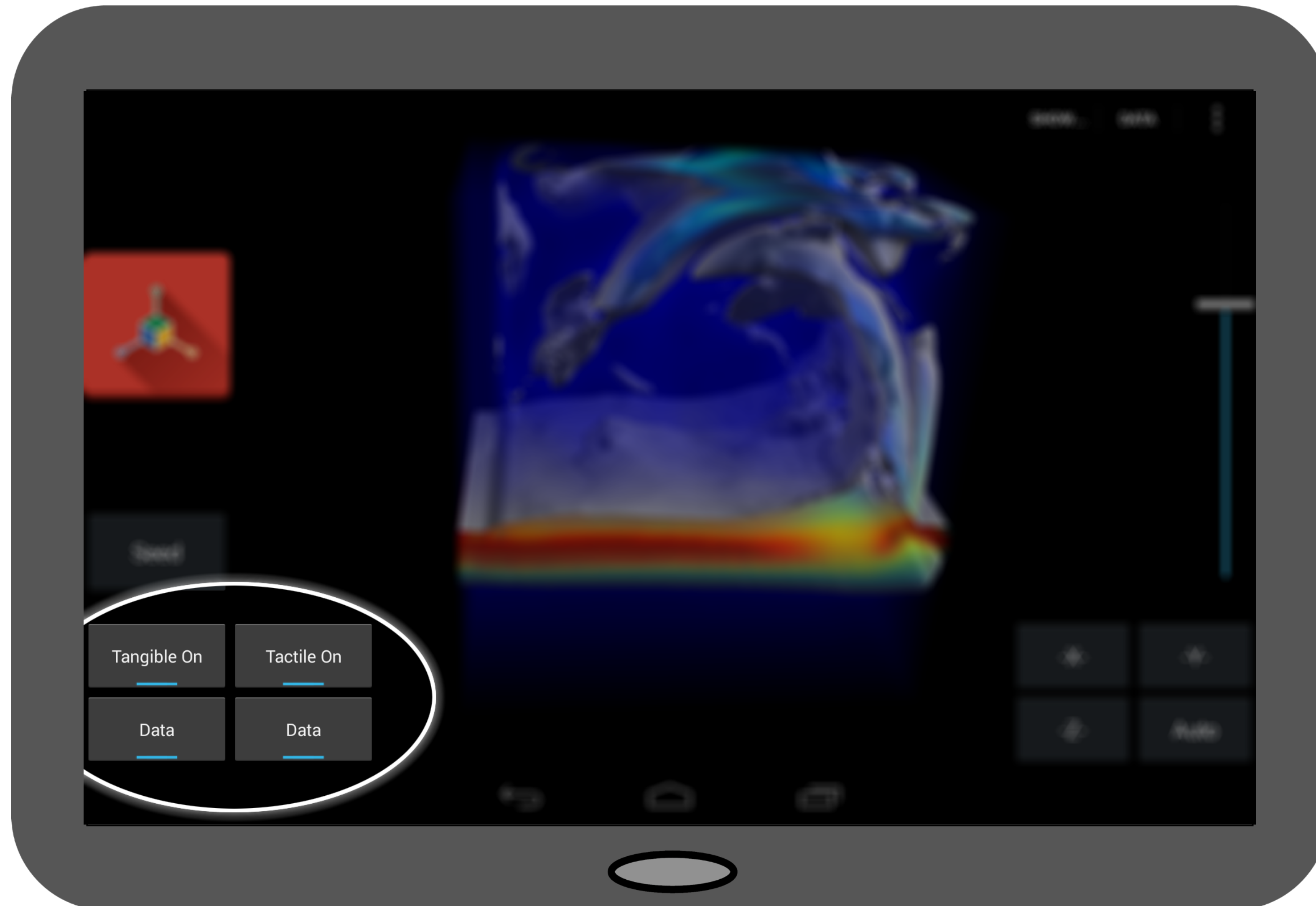

# User Interface

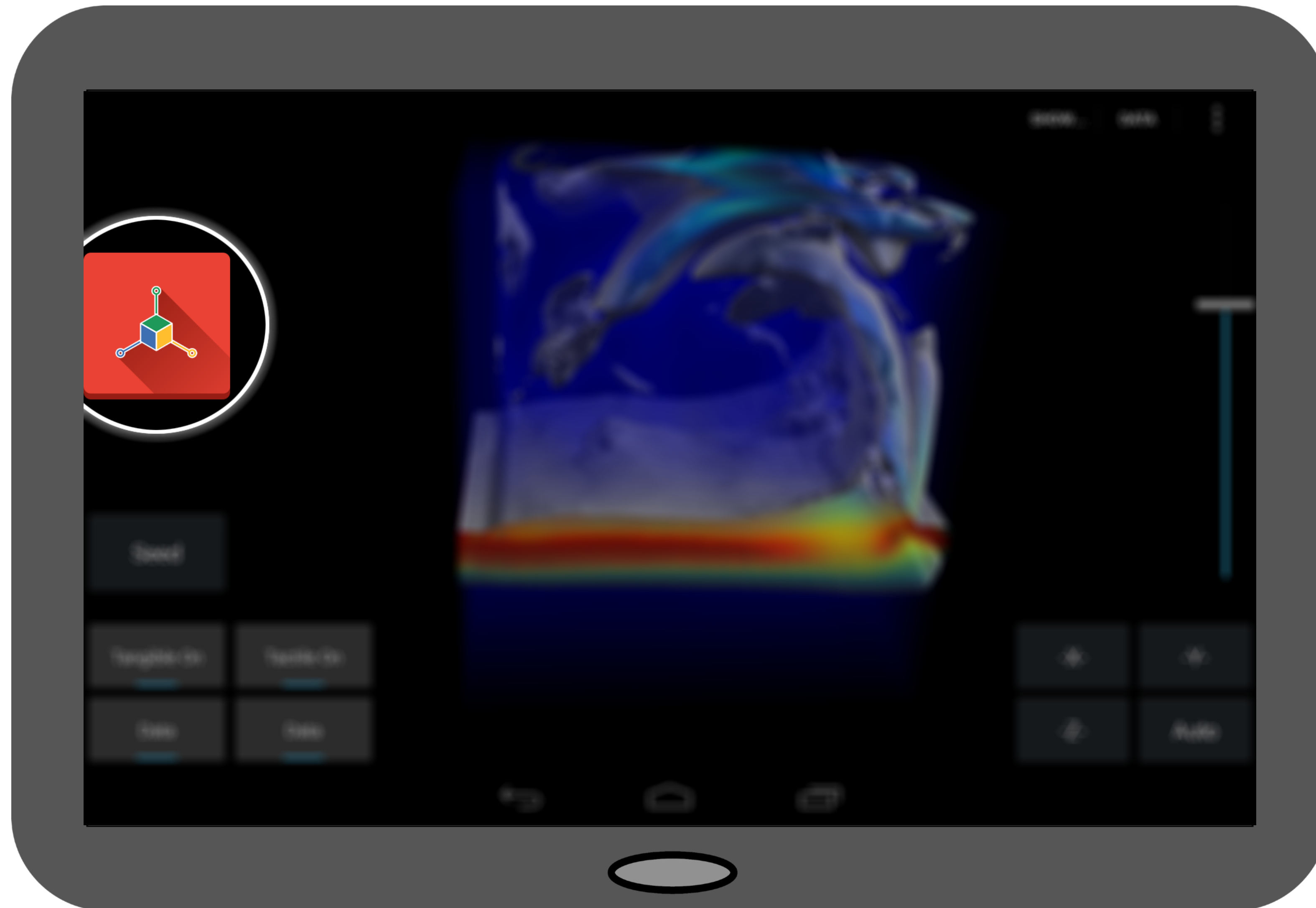

# User Interface

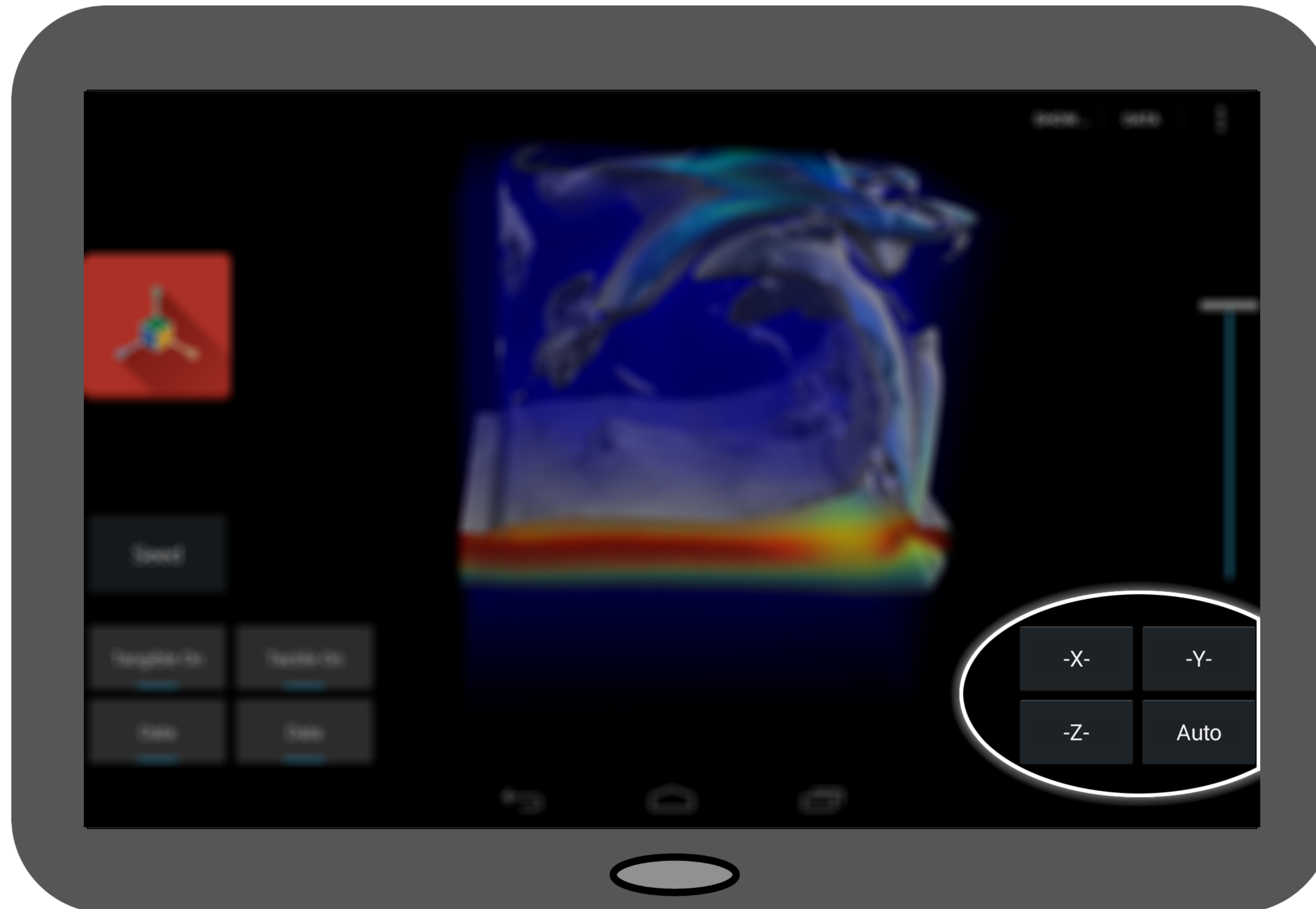

# User Interface

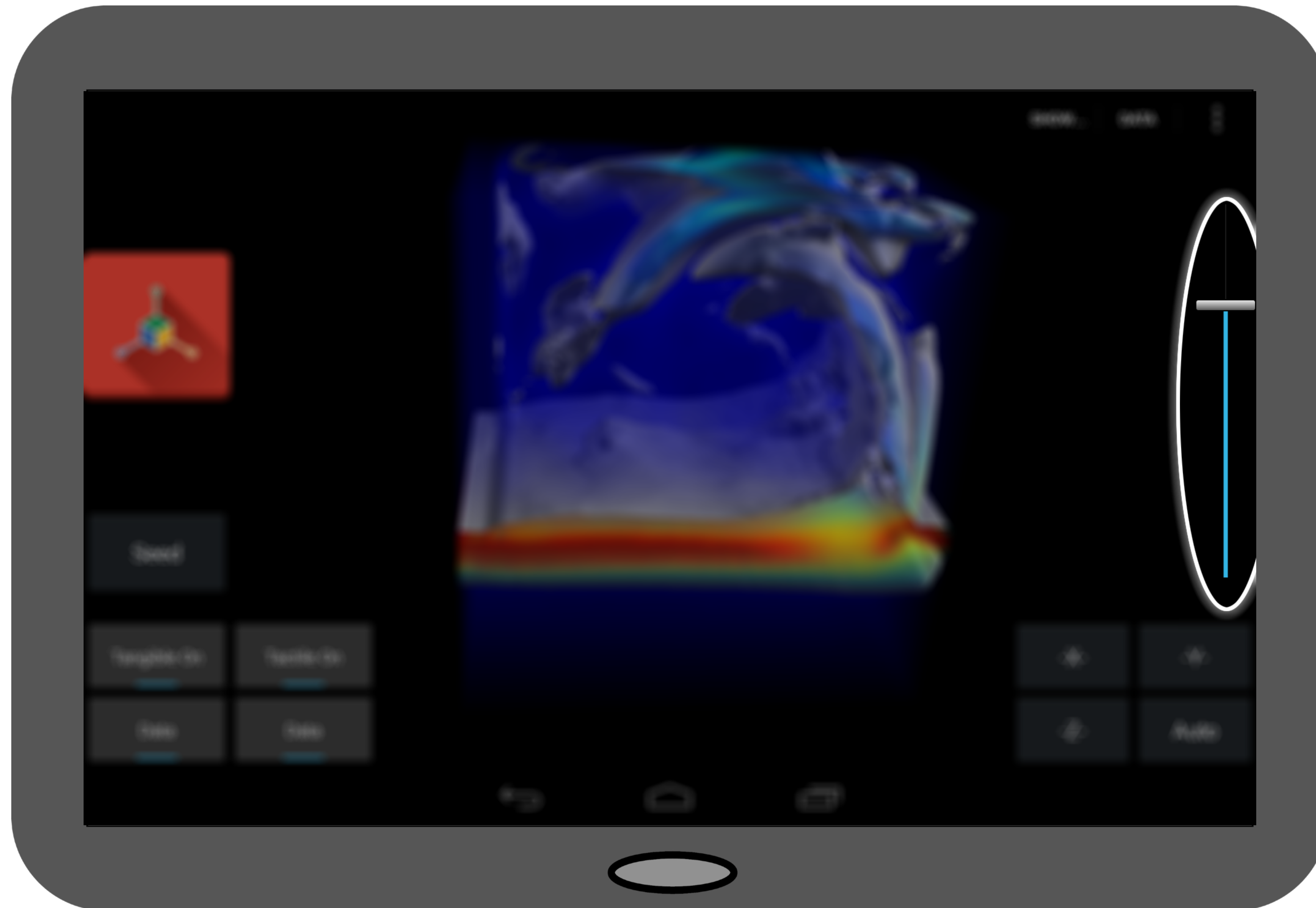

# 3D data space navigation

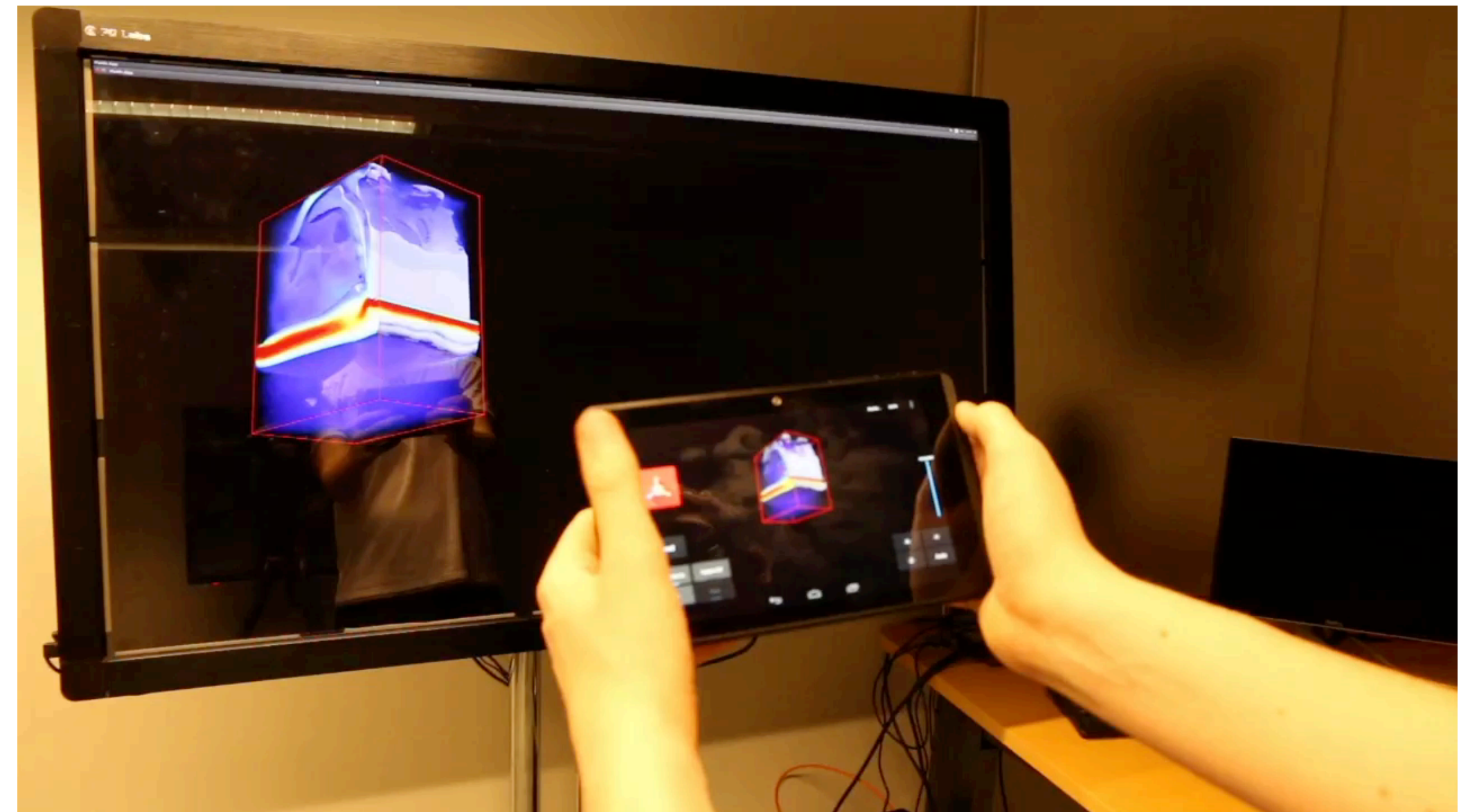
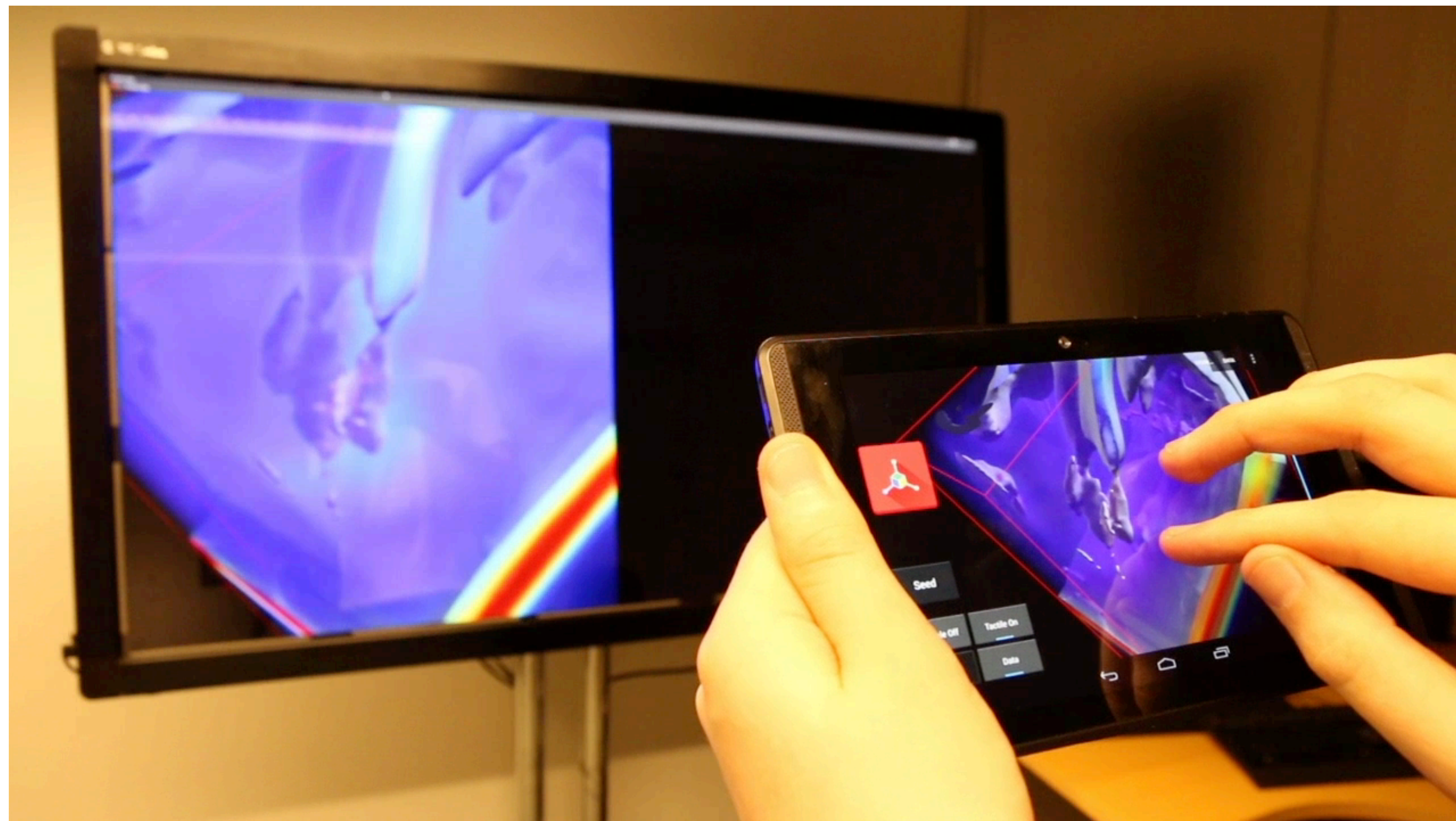
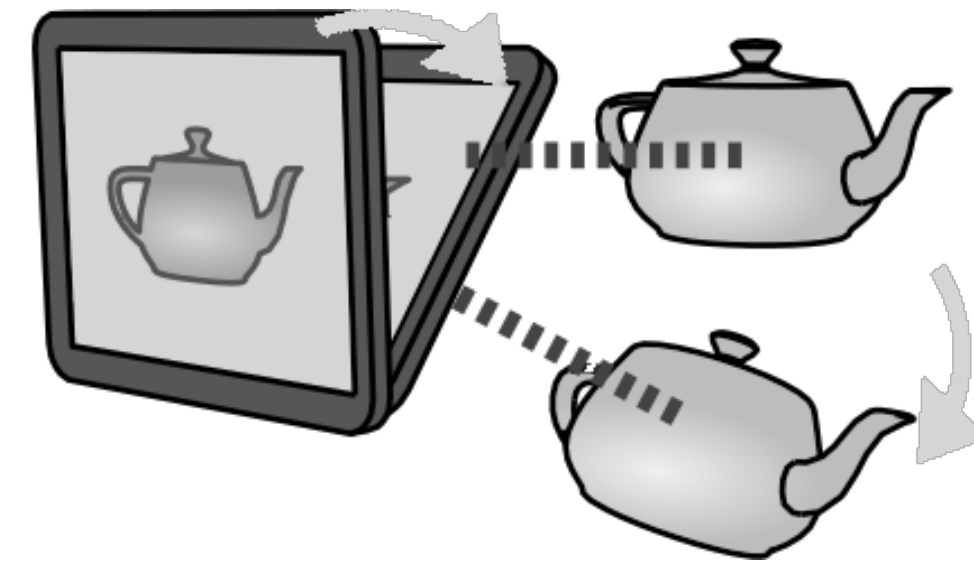
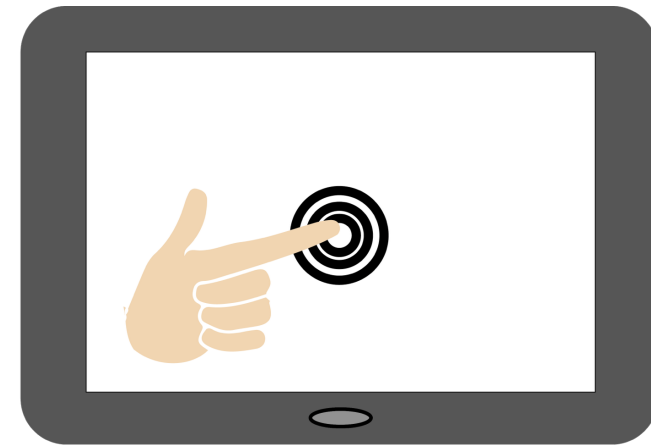

# 3D cutting plane manipulations

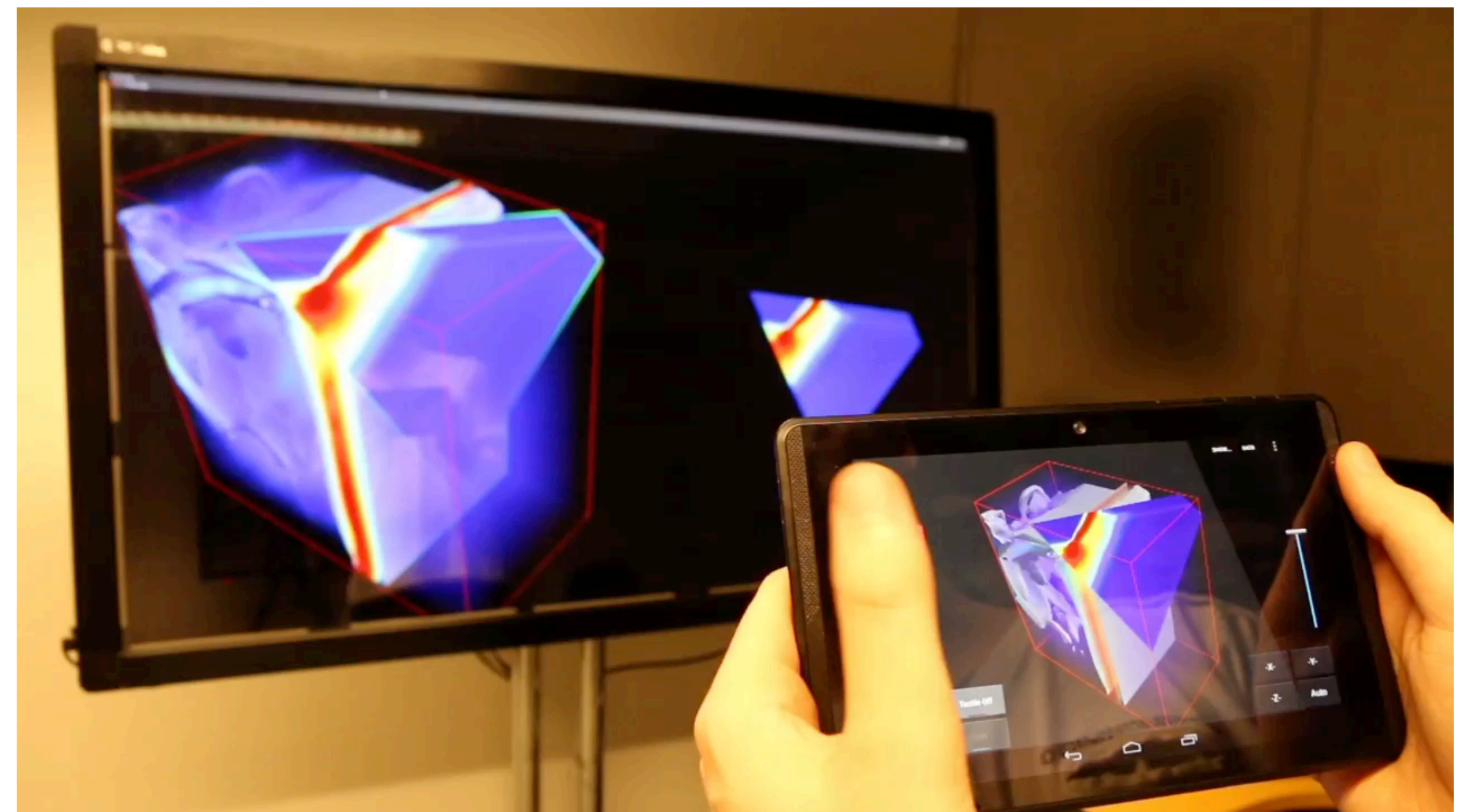
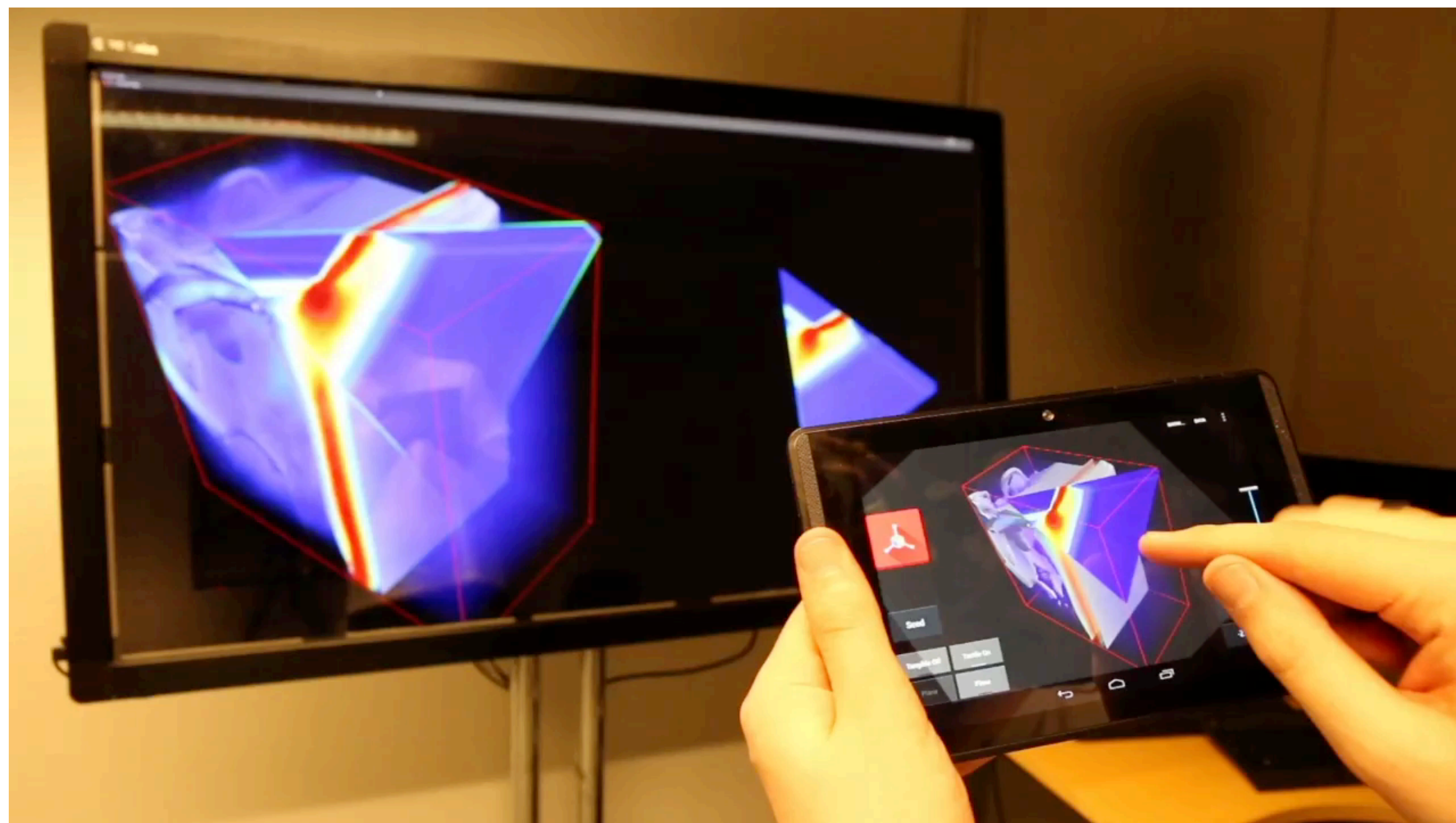
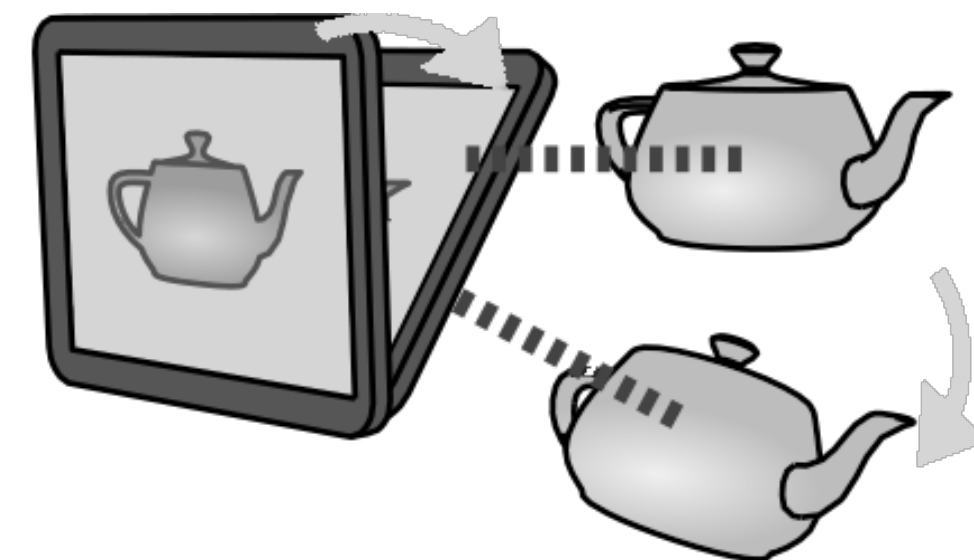
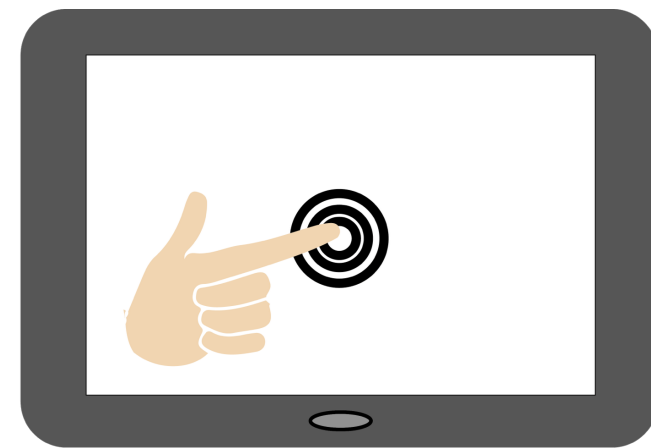



# Hybrid Tactile/Tangible manipulations

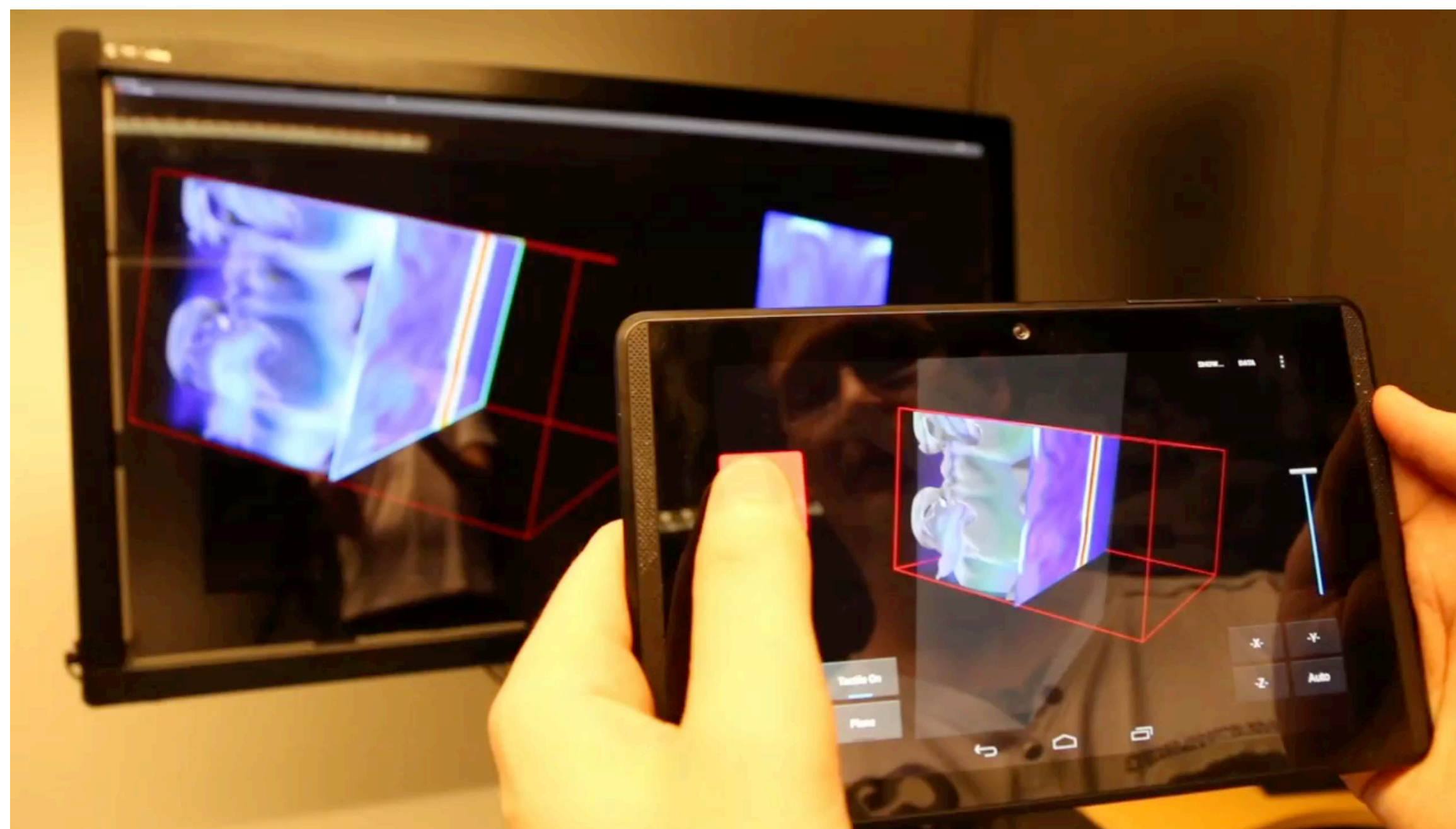
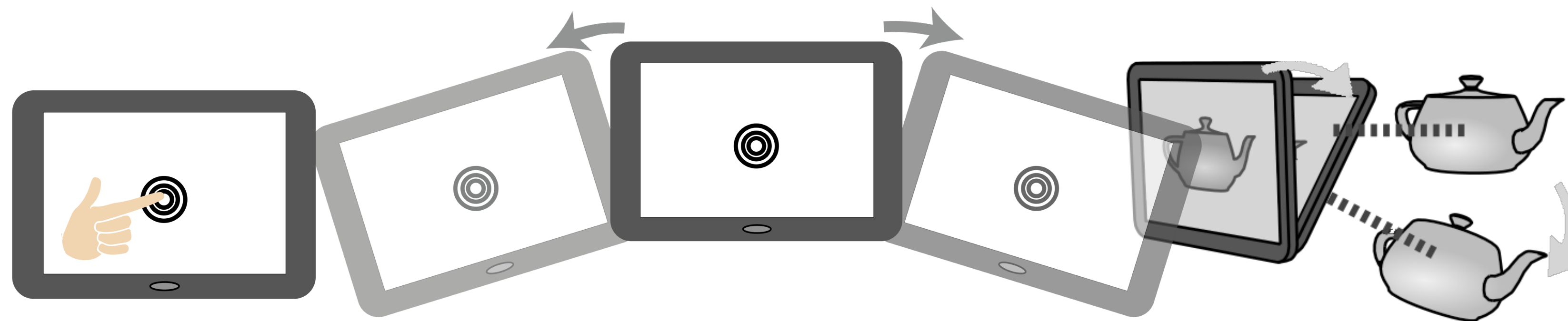

# Gain-factor manipulations

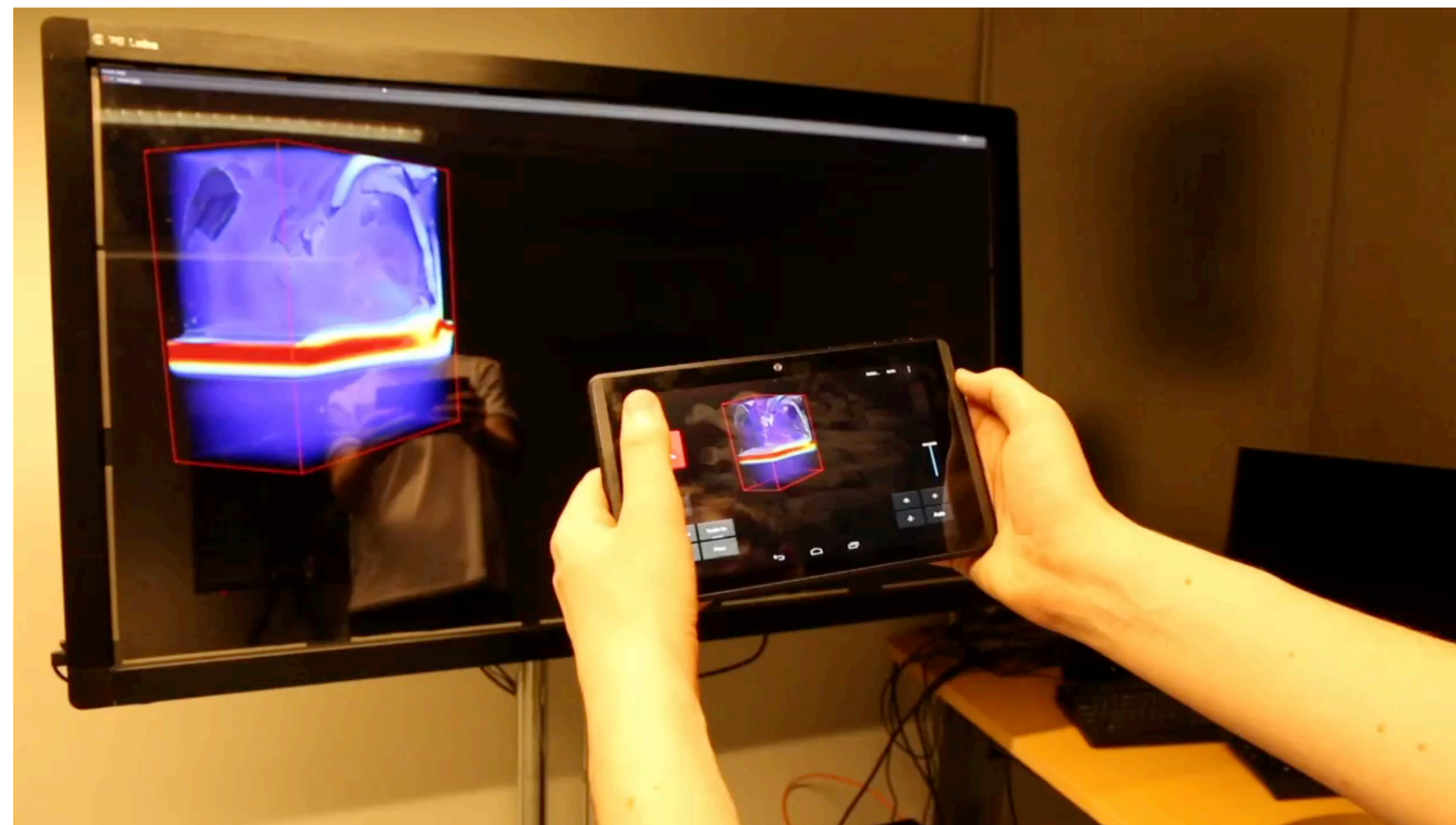
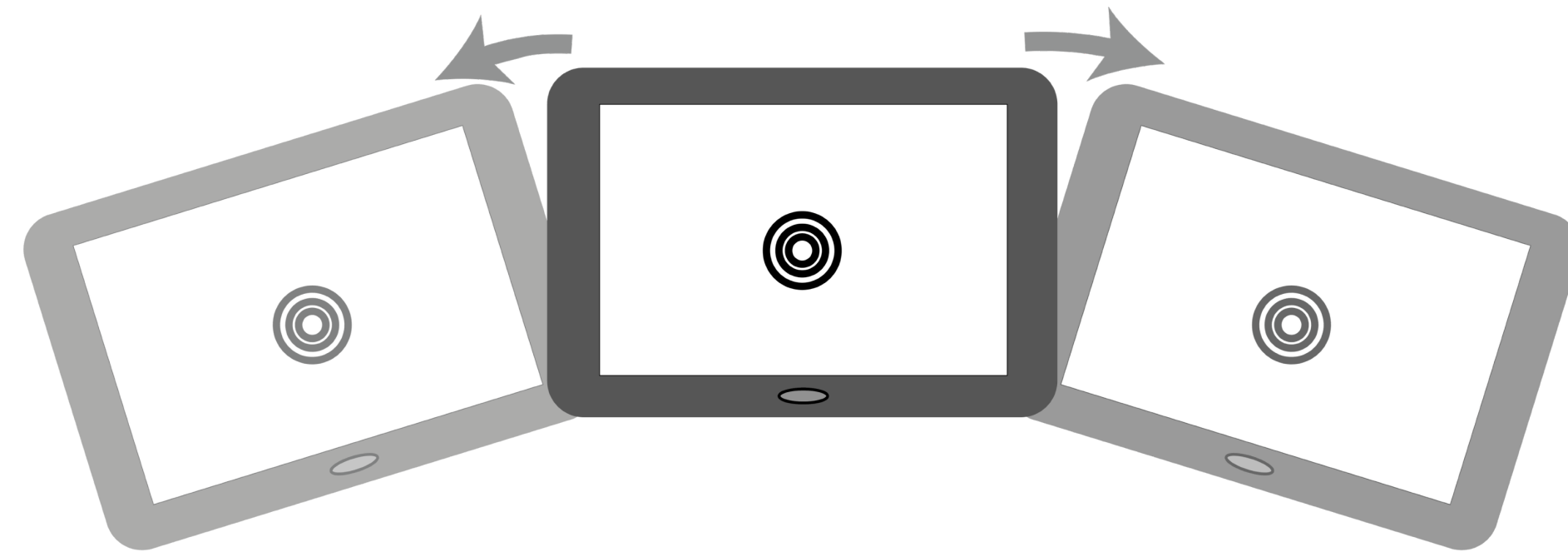

# Seeding point Placement

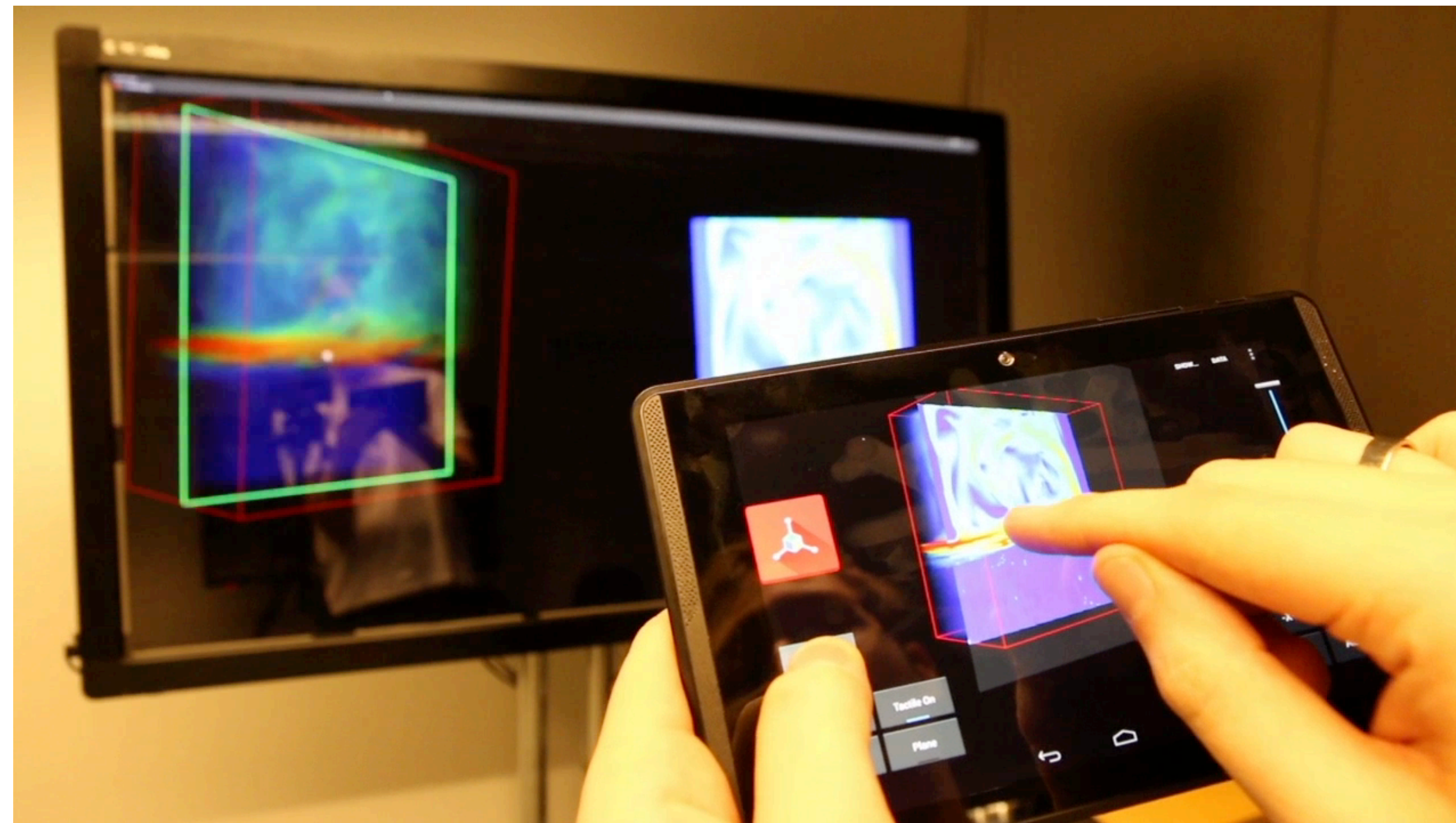
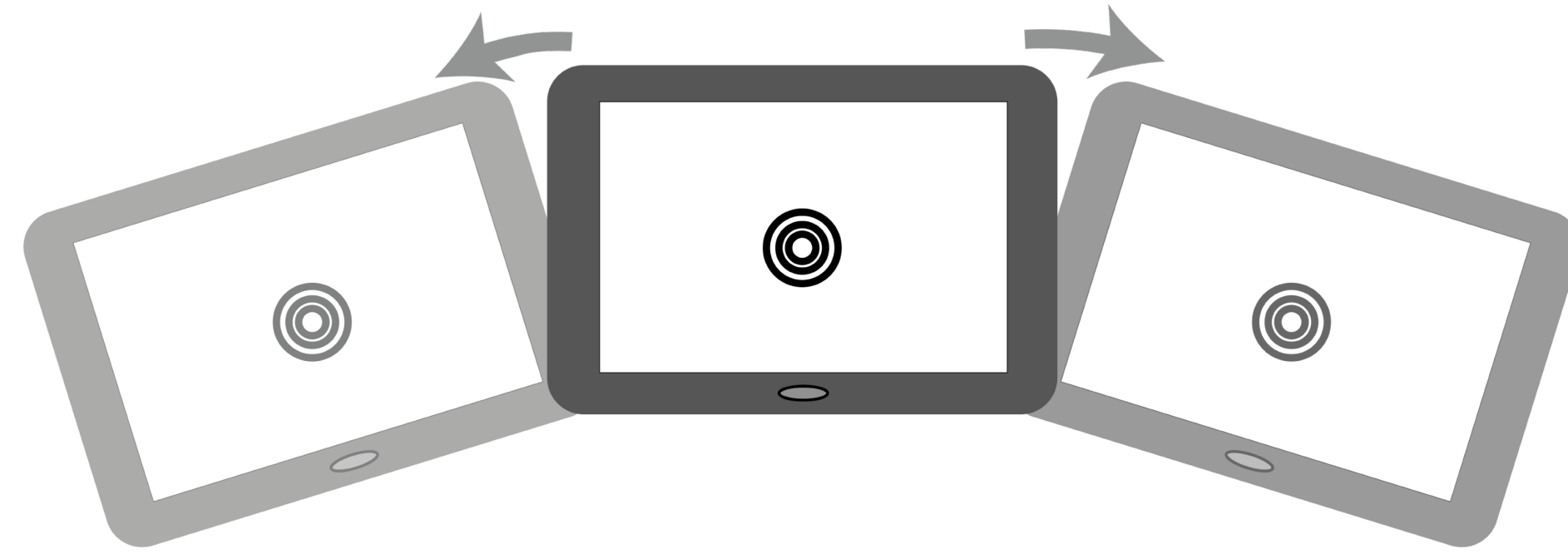

# Hybrid Interaction Study

- 7 fluid dynamic researchers (mean 12.8 years of experience)
- Free exploration task with a FTLE dataset
- Questionnaires

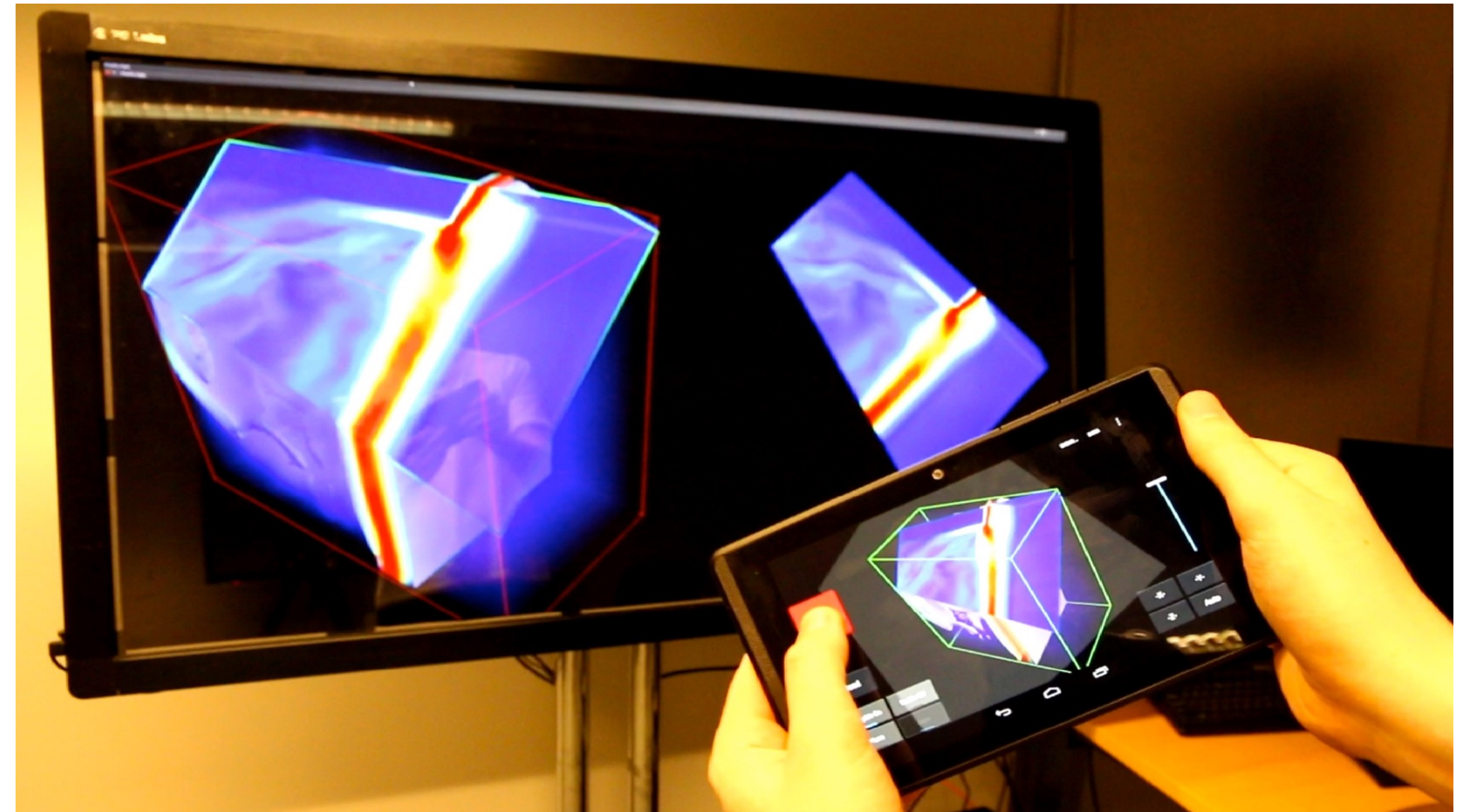

# Quantitative Results

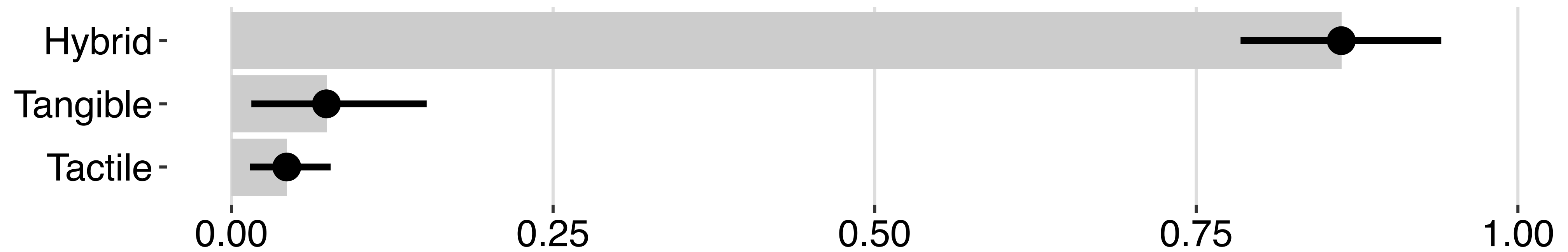

ratio of time spent interacting in the different conditions, error bars 95% CI

# Quantitative Results

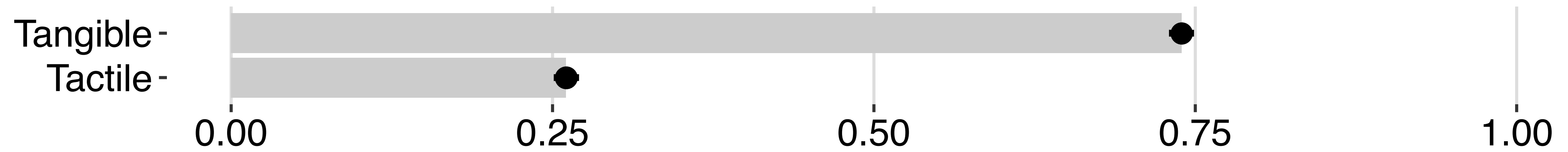

ratio of time spent using the tactile and tangible conditions in hybrid, error bars 95% CI

# Quantitative Results

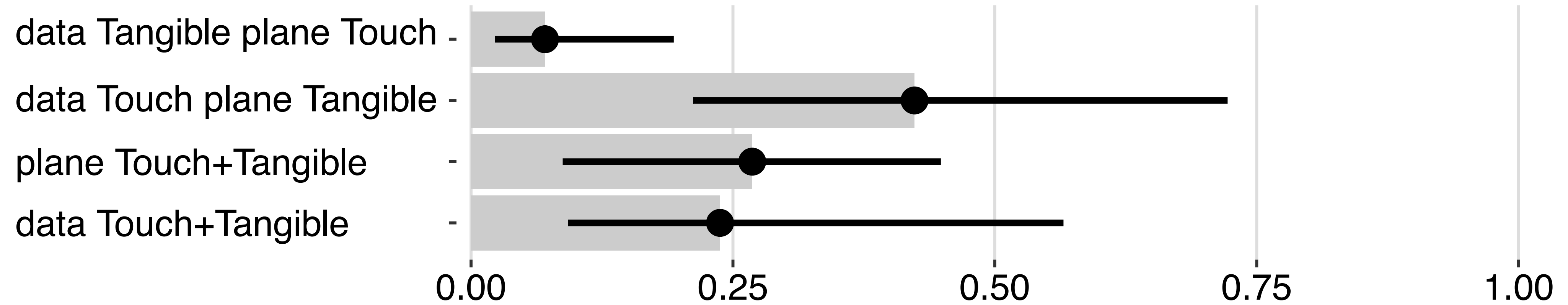

ratio of time spent interacting with the different plane/data associations in Hybrid Interaction, error bars 95% CI

# Qualitative Results: Preferences

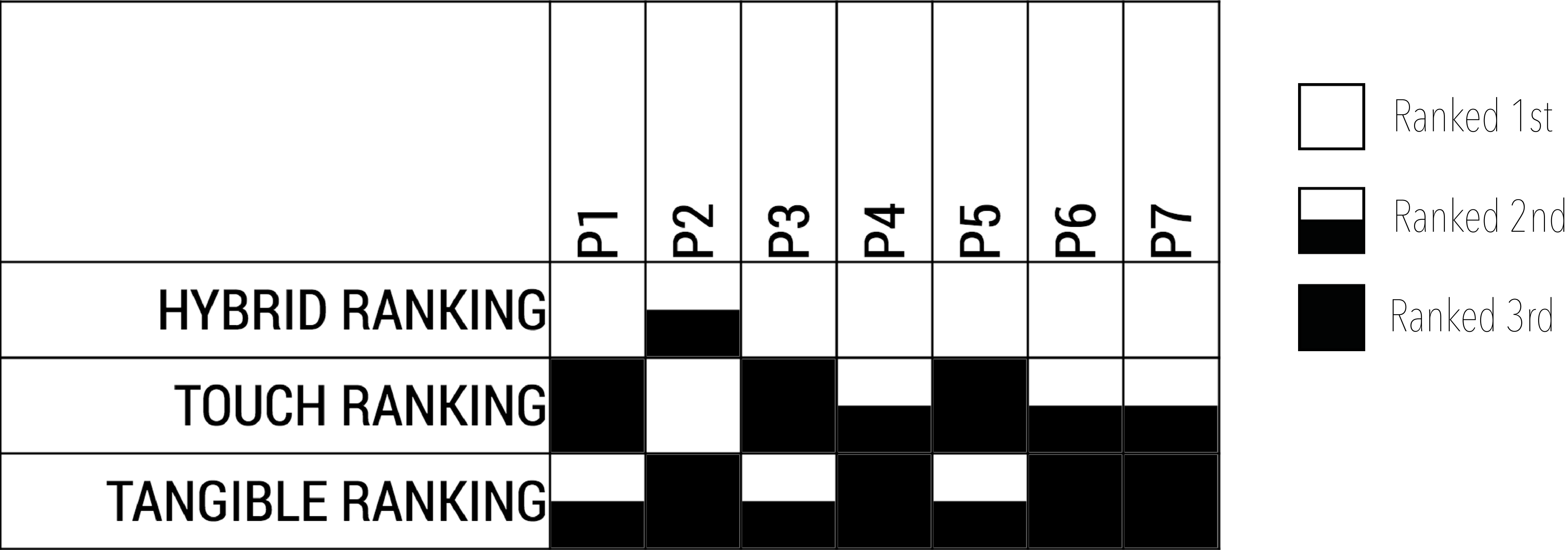



# Qualitative Results

- "The system is a reproduction of what I can do with a PC but with better interaction techniques"
- "Seed point placement is more engaging and flexible"
- "I could achieve rotations or translation difficult to perform with a mouse-only approach"
- "Could be used as an extra visualization tool for primary analysis before getting back to a PC for more in depth analysis that requires scripts"

# Qualitative Results

- Only 1 participant did not consider the tool as being fit for practical work yet
- 5 participants would gladly use it if synchronises with their desktop stations

# Limitations

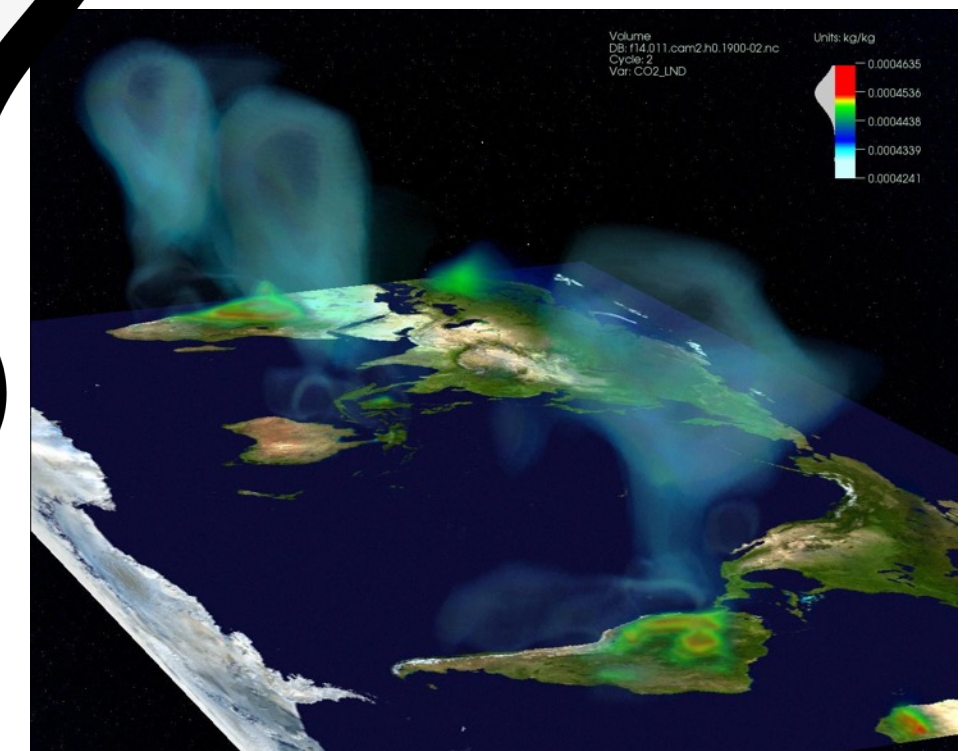
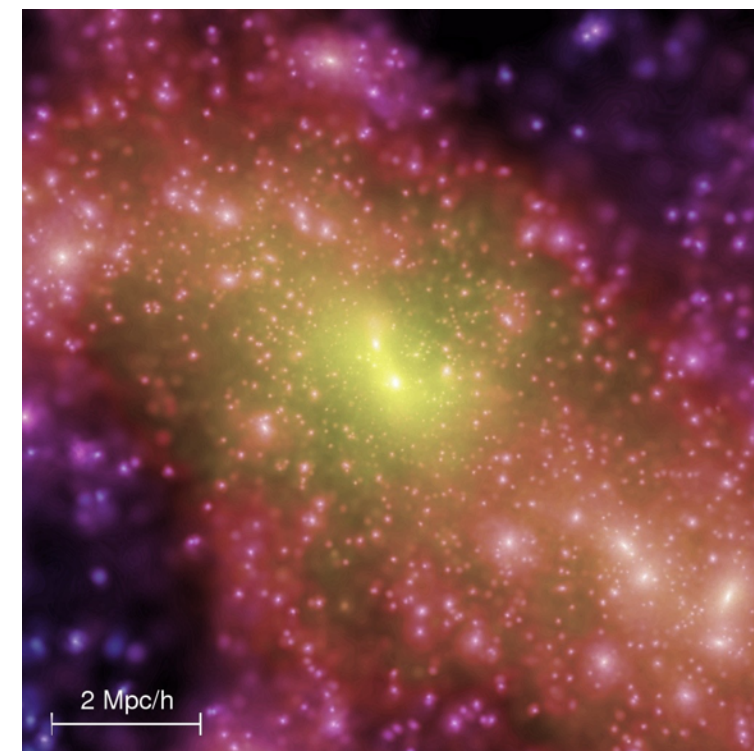
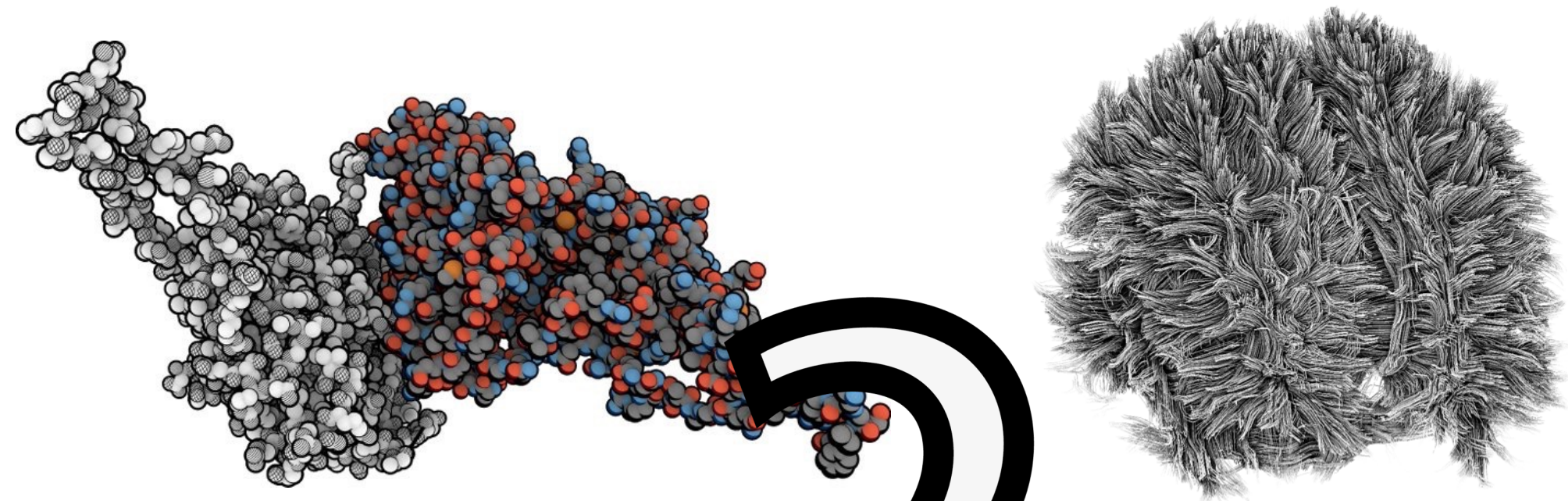
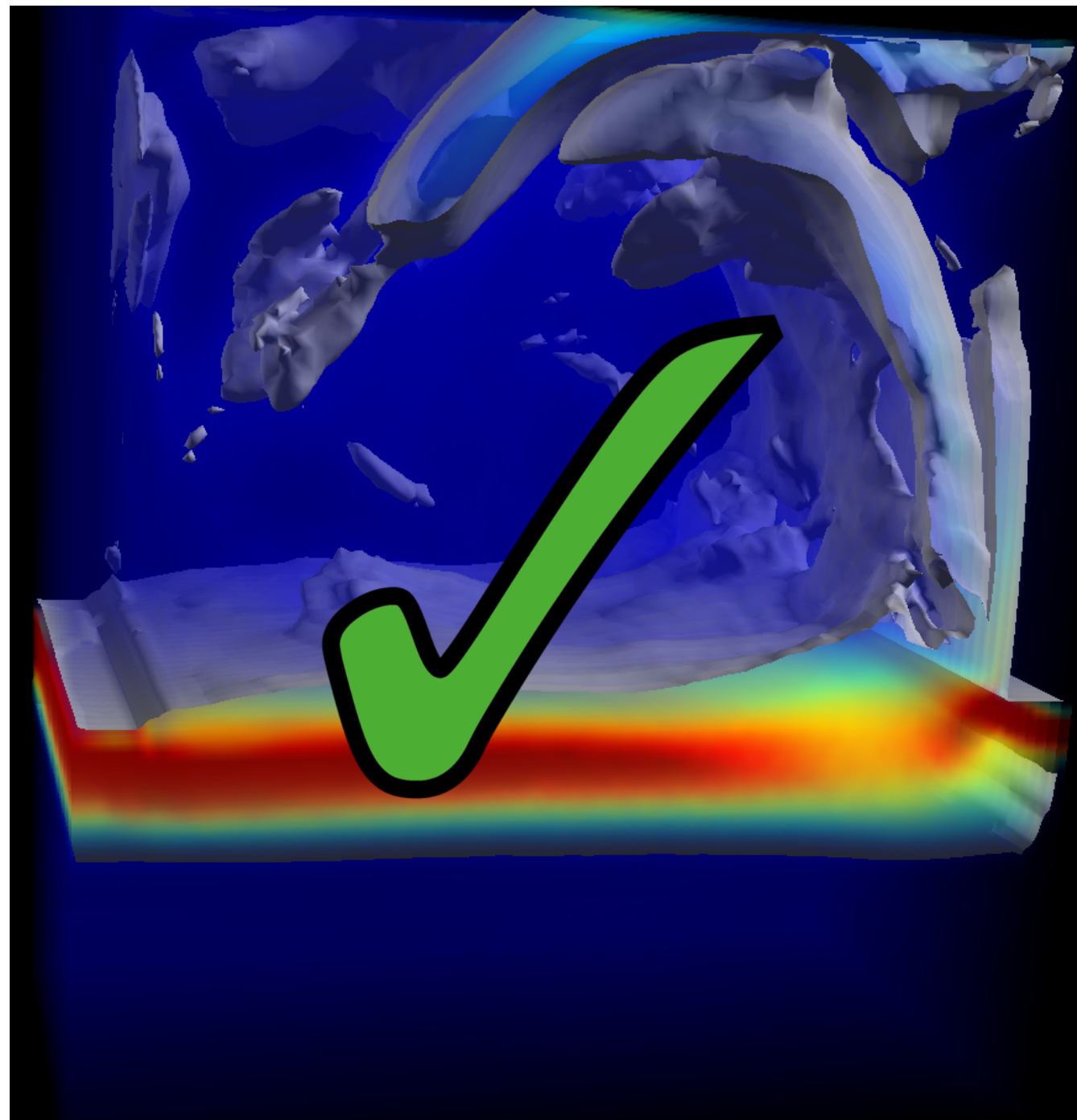

# Limitations

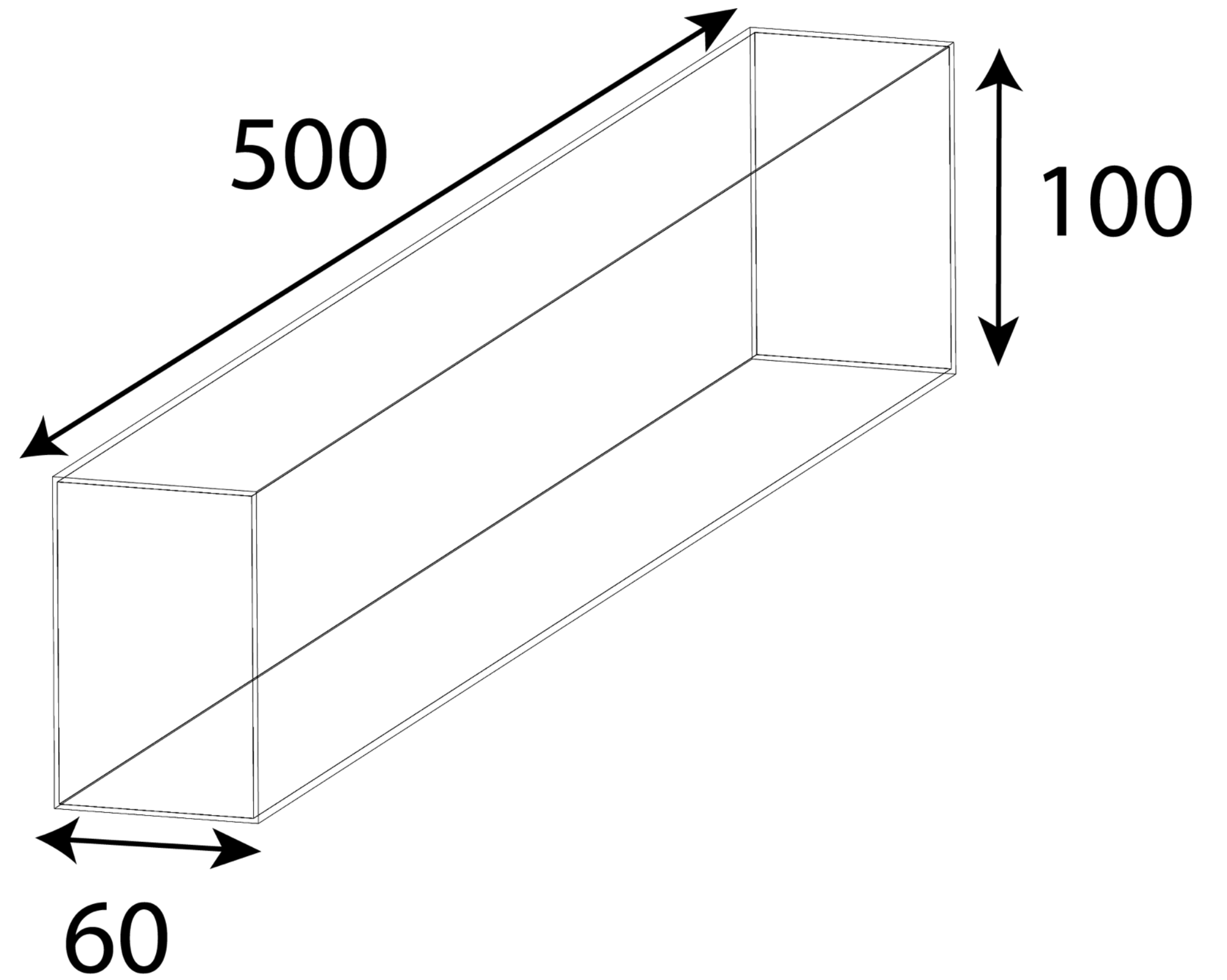
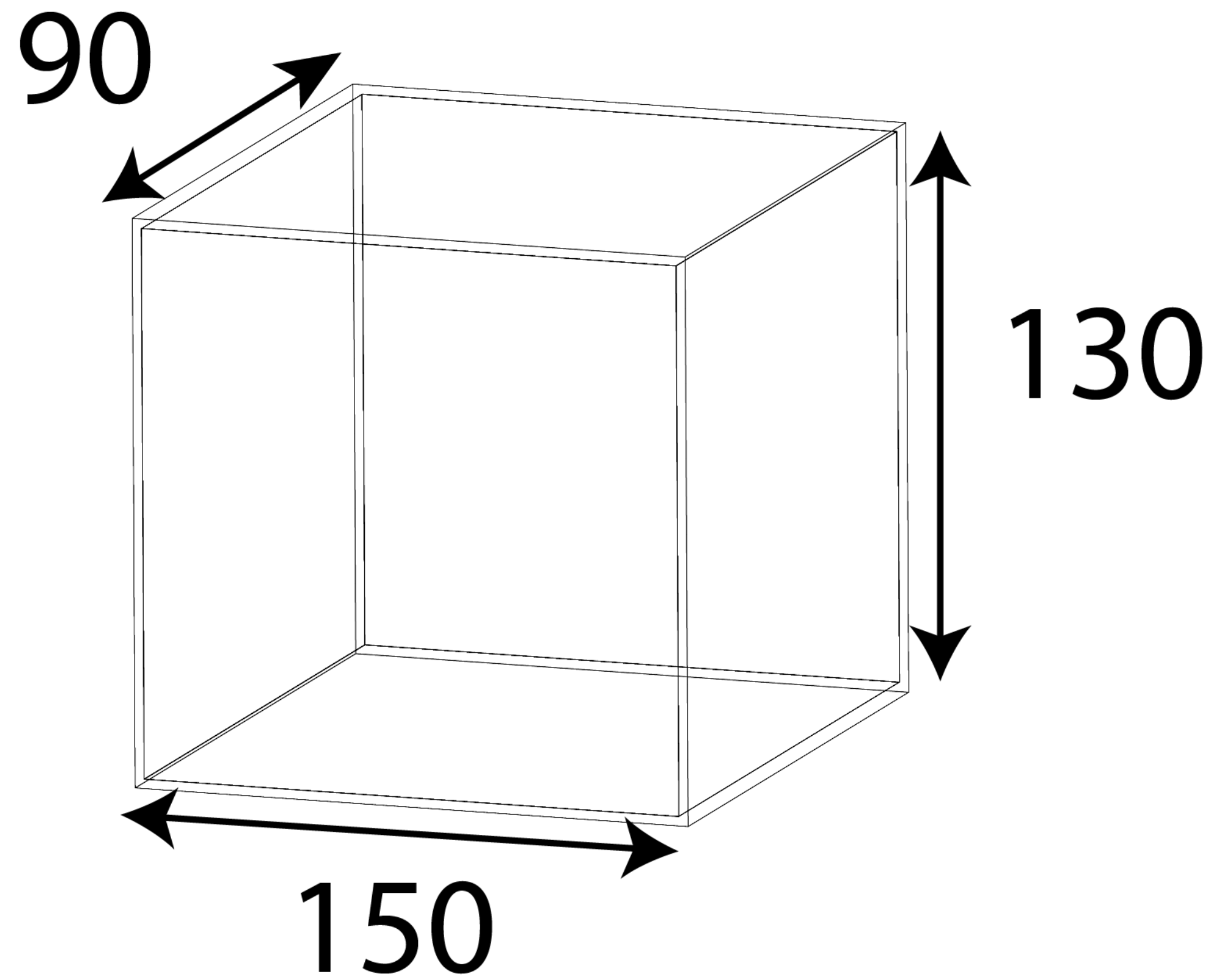

# Limitations

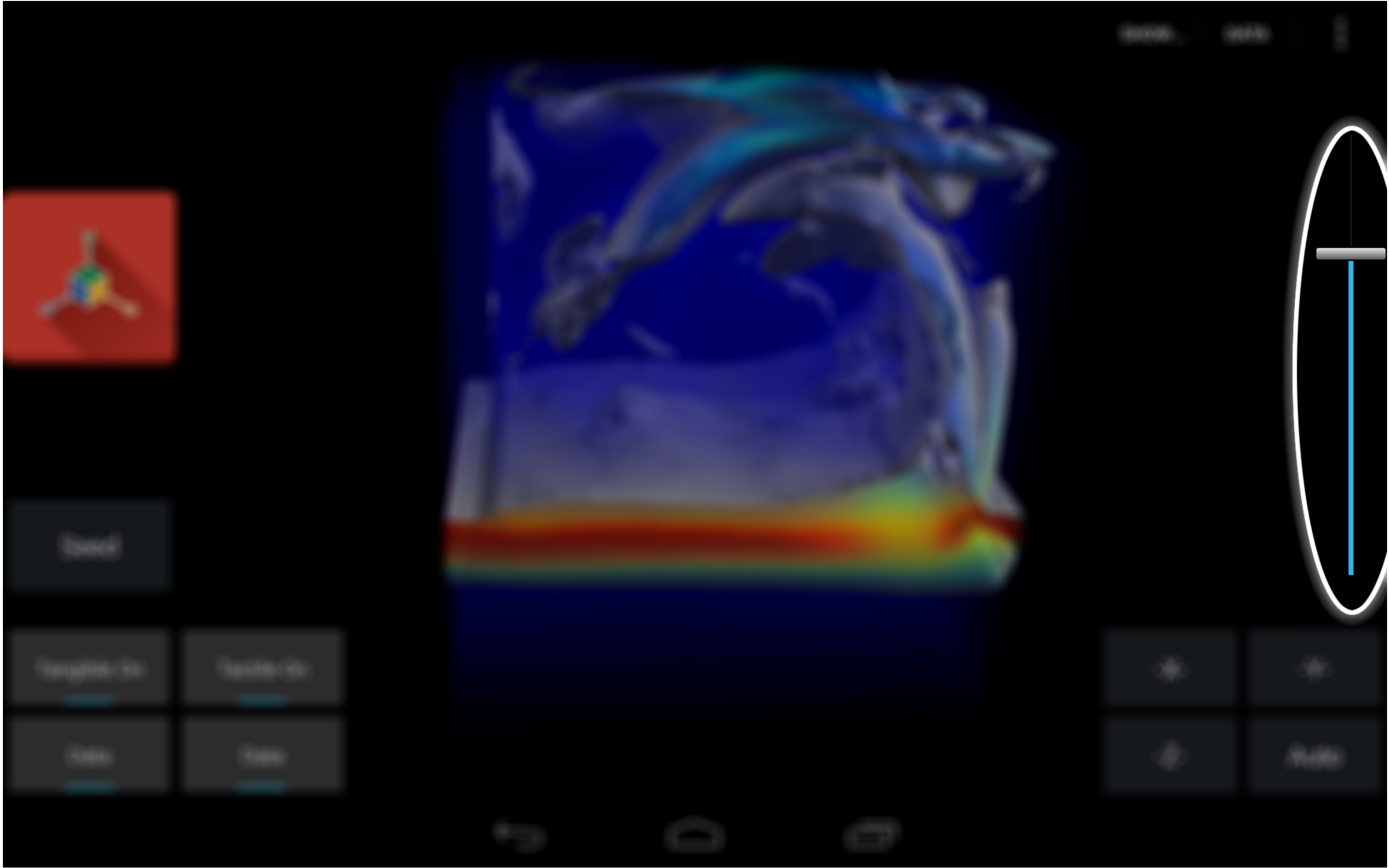

# Conclusion

- Hybrid interaction possible with off-the-shelves hardware
- Complex tasks easily achieved with a hybrid tactile/tangible input
- Hybrid seed point placement is more flexible
- Hybrid interaction is largely preferred

# Interactive 3D Data Exploration Using Hybrid Tactile/Tangible Input

Lonni Besançon, Paul Issartel, Mehdi Ammi, Tobias Isenberg

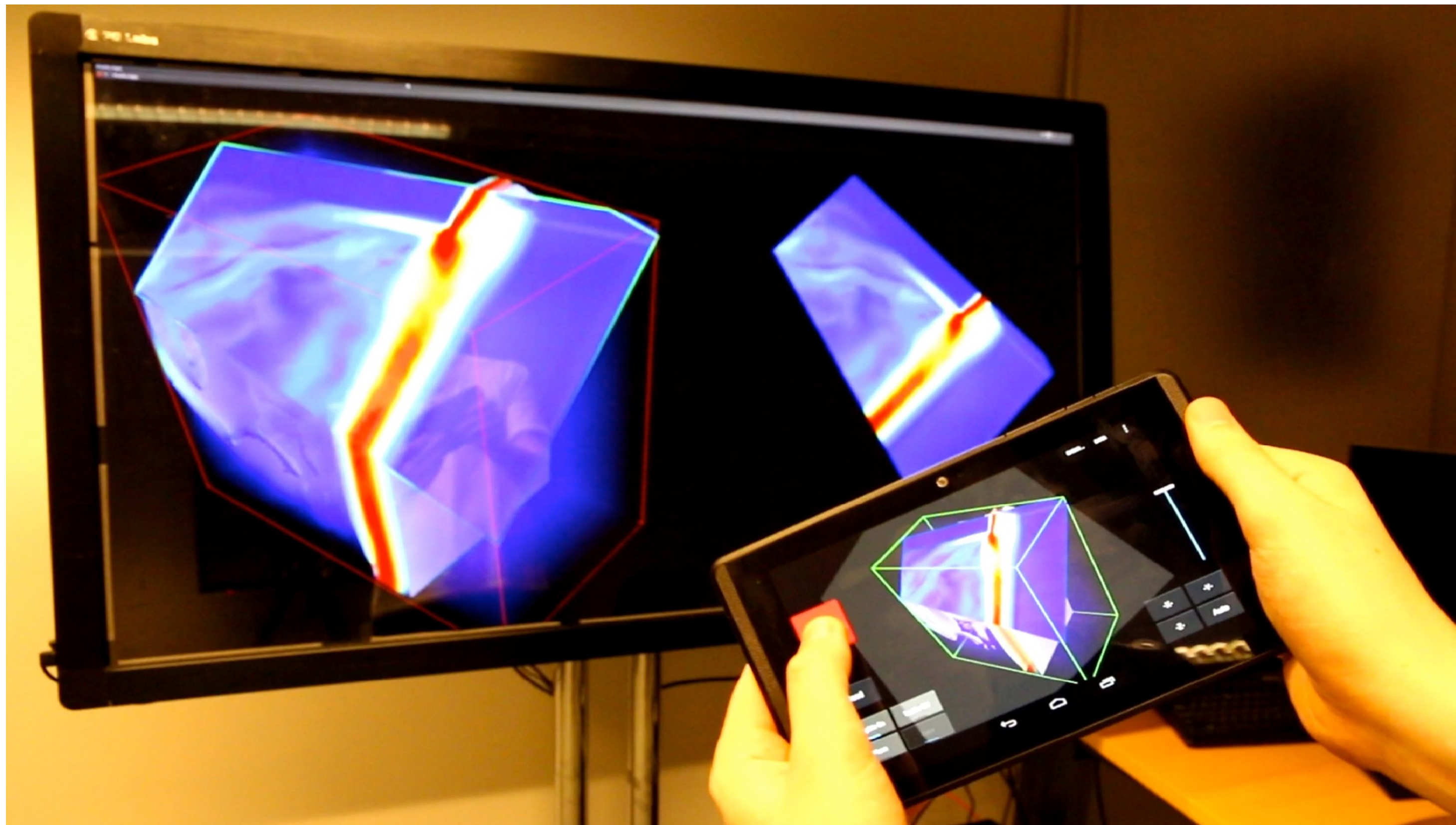

<http://tiny.cc/hybridinteraction>